

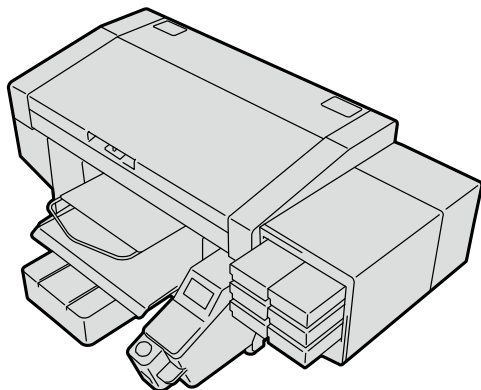

Please be sure to read this manual before using this product.
Keep this manual in a safe place for future use.







GTX pro

**GARMENT PRINTER
Setup Manual**

Table of contents

Please be sure to read "SAFETY INSTRUCTIONS" before use.

	Installation	1
	Setup of the printer	5
	Connection to a PC	18
	Adjustment	24
	Maintenance list	28

SAFETY INSTRUCTIONS

Thank you very much for buying a BROTHER printer. Before using your new printer, please read the "SAFETY INSTRUCTIONS" and handling instructions carefully.



SAFETY INSTRUCTIONS

1. Safety indications and their meanings

This instruction manual and the indications and symbols that are used on the printer itself are provided in order to ensure safe operation of this printer and to prevent accidents and injury to yourself or other people.

The meanings of these indications and symbols are given below.

Indications

 DANGER	The instructions which follow this term indicate situations where failure to follow the instructions will result in death or serious injury.
 WARNING	The instructions which follow this term indicate situations where failure to follow the instructions could result in death or serious injury.
 CAUTION	The instructions which follow this term indicate situations where failure to follow the instructions may result in minor or moderate injury.

IMPORTANT

The instructions which follow this term indicate situations where failure to follow the instructions may result in damage to property.

NOTE

The instructions which follow this term indicate precautions and restrictions for use.

Symbols



This symbol () indicates something that you should be careful of. The picture inside the triangle indicates the nature of the caution that must be taken. (For example, the symbol at left means "beware of injury".)



This symbol () indicates something that you must not do.



This symbol () indicates something that you must do. The picture inside the circle indicates the nature of the thing that must be done. (For example, the symbol at left means "you must make a ground connection".)

2. Notes on safety

DANGER



Contact with high voltage sections may lead to a serious injury. Turn off the power, and remove the cover 5 minutes later.

WARNING

Basic precautions



To prevent accidents and problems, do not modify the machine yourself. Brother will not be held responsible for any accidents or problems resulting from modifications made to the machine.



Do not handle the power cord with wet hands. Otherwise, it may cause electric shocks.

Installation



Do not set up the printer in a dusty environment. If dust collects inside the printer, it may cause fire or electric shocks or problems with correct operation.



Be sure to connect the ground. If the ground connection is not secure, you run a high risk of receiving a serious electric shock, and problems with correct operation may also occur.



Do not bend the cords excessively or fasten them too hard with staples or anything similar to secure cords. Otherwise it may cause fire or electric shocks.



Printing



If a foreign object gets inside the printer, immediately turn off the power, disconnect the power cord, and contact the place of purchase or a qualified technician. If you continue to use the printer while there is a foreign object inside, it may result in fire or electric shocks or problems with correct operation.



Do not allow the printer to come into contact with liquids. Otherwise it may cause fire or electric shocks or problems with correct operation.











If any liquid gets inside the printer, immediately turn off the power, disconnect the power cord, and contact the place of purchase or a qualified technician.









Do not use the printer when smoke or a bad odor is coming from the printer. Otherwise it may cause fire or electric shocks or problems with correct operation. Immediately turn off the power, disconnect the power cord, and contact the place of purchase or a qualified technician.



 WARNING	
Printing	
	Keep your finger or any body part away from the rotating fan. Otherwise it will be caught up, which results in injuries. Turn off the power when you approach the fan.

 CAUTION	
Environmental requirements	
	Use the printer in a place which is adequately ventilated. A slight odor is generated when the printed articles are being fixed by heat.
Installation	
	Setting up and moving of the printer should only be carried out by a qualified technician.
	The printer machine weighs 128 kg (282 lb). Transporting and setting up of the printer should be held in the proper way. Otherwise it may fall down and cause injury.
	
	When the printer falls down, disconnect the power cord and contact the place of purchase or a qualified technician. If you continue to use it, it may result in fire or electric shocks or poor printing quality.
	

	Do not place the printer on a shaky table or high shelf or other unstable location. Otherwise it may tip over or fall down and cause injury. Furthermore, the table that supports the machine should be at least 35.4 in. (90 cm) in width and 23.6 in. (60 cm) in depth, and should be able to bear a weight of 150 kg (330 lb) or more.
	Do not set up the printer in a place where it will be affected by vibration. Otherwise the printing quality may be degraded or the printer may fall down, which causes injury or results in failure of the printer.
	Do not connect the power cord until installation is complete. The printer may operate if the power is turned on by mistake, which could result in injury.
	Do not climb onto the printer or place heavy objects on top of it. Otherwise it may become unbalanced and tip over or fall down and cause injury.
	Be careful not to touch the claws of the mounting portion on the upper side of the rear cover. Otherwise you may be injured.
Printing	
	This printer should only be used by operators who are appropriately trained in its safe operation.

CAUTION

Printing



Ensure there is adequate space left in front of the printer and avoid placing any objects. Otherwise your hand may get caught between the platen and an object, which may result in injury.



Do not handle the platen while printing. If your hand gets caught between the platen or the T-shirt tray and the covers, it may be injured.



Do not put your hands inside the covers while the printer's power is turned on. Otherwise your hands may touch against moving parts and this may result in injury.



When the pretreatment is applied to printed objects (like a T-shirt) with a spray or pretreatment applicator, sprayed mist is generated. So wear a pair of plastic gloves, a mask and protective glasses (or goggles) designed to shield against liquid splash, and fully take care of the air ventilation when you are working with it.



When a problem occurs with the operation of the printer, contact the place of purchase or a qualified technician.

Maintenance



Be careful not to get your fingers caught when closing the front cover, otherwise it may result in injury to your fingers.



When you mount or replace the head, be careful not to get your hands or fingers caught. Otherwise you may be injured.



Do not disassemble the ink pouch. If the ink gets into your eyes or onto your skin, it may cause inflammation. In case of contact with eyes, do not rub but immediately rinse the eyes with water.





Do not drink liquids such as the ink, maintenance solution, cleaning solution, pretreatment, or waste. They may cause diarrhea or vomiting. Avoid causing your eyes or skin to make contact with the ink, maintenance solution, cleaning solution, pretreatment or waste. It may cause inflammation. In case of contact with eyes, do not rub but immediately rinse the eyes with water. Keep the liquids out of the reach of children.



Be sure to wear protective goggles and gloves when handling the grease, so that it does not get into your eyes or onto your skin. It can cause inflammation. Do not drink or eat the grease. It may cause diarrhea or vomiting. Keep the liquids out of the reach of children.



CAUTION

Maintenance





-  When replacing parts and installing optional accessories, be sure to use only genuine Brother parts. Brother will not be held responsible for any accidents or problems resulting from the use of non-genuine parts.
-  When replacing parts or installing optional accessories, be sure to follow the procedures described in the Instruction Manual. Incorrect procedures could cause injuries or problems.

IMPORTANT

Printing

-  Do not move the platen by hand. Otherwise the printer may be mechanically and electrically damaged.
-  Ensure there is adequate space left in front of the printer and avoid placing any objects. The platen may be hit and damaged.

NOTE

-  Use the printer in an area which is free from sources of strong electrical noise such as electrical line noise or static electric noise. Sources of strong electrical noise may cause problems with correct operation.
-  Any fluctuations in the power supply voltage should be within $\pm 10\%$ of the rated voltage for the printer. Voltage fluctuations which are greater than this may cause problems with correct operation.
-  The power supply capacity should be greater than the requirements for the printer's power consumption. Insufficient power supply capacity may cause problems with correct operation.
-  In the event of an electrical storm, turn off the power and disconnect the power cord from the wall outlet. Lightning may cause problems with correct operation.
-  The printer is not suitable for use in places where children are present.



<About trademarks>

The names of operating systems described in the main context of this manual are abbreviated. Product names used in this manual are, in general, trademarks or registered trademarks of their respective developer or manufacture. However, in this manual, the ® marks or TM marks are not used.

Brother logo is registered trademark of Brother Industries, Ltd. Apple, Macintosh, Mac OS, iOS, OS X, macOS, Safari, iPad, iPhone, iPod and iPod touch are the trademarks or registered trademarks of Apple Inc. in the United States and other countries.

The official name of Windows® 10 is Microsoft® Windows® 10 operating system. (represented as Windows 10 in this manual)

The official name of Windows® 11 is Microsoft® Windows® 11 operating system. (represented as Windows 11 in this manual)

Microsoft®, Windows® 10, and Windows® 11 are trademarks and registered trademarks of Microsoft Corporation in the United States of America and other countries.

Other product and company names mentioned herein may be the trademarks or registered trademarks of their respective owners.

Information in this document and the specifications of this product are subject to change without notice.

<About the CE declarations>

Downloadable from: <https://www.brother.com>

SAFETY INSTRUCTIONS

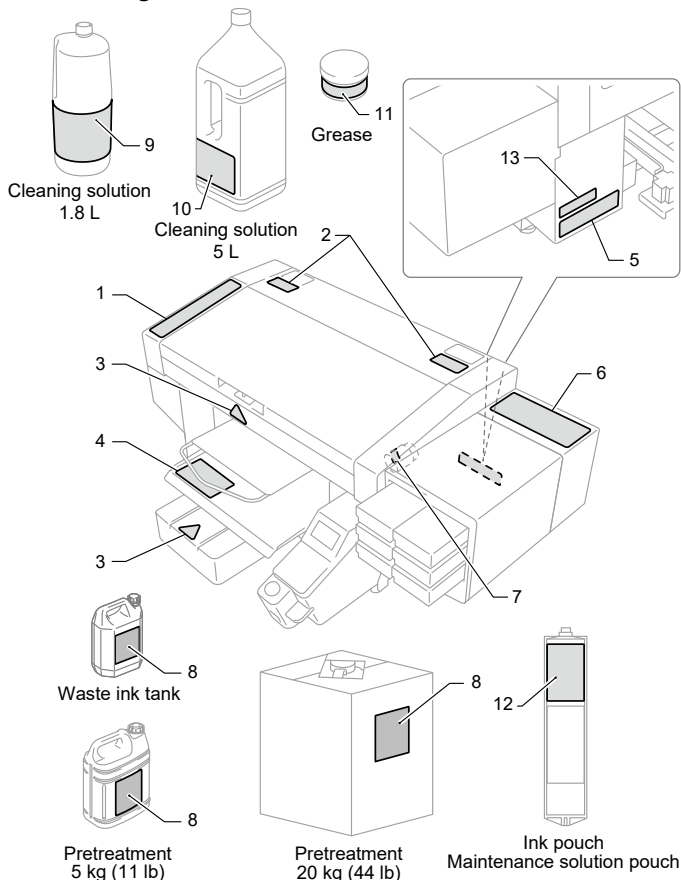

3. Warning labels



This printer has the following warning labels displayed on it. Follow the precautions given on each warning label for your work.

When the label is peeled off or illegible, contact the place of purchase.

1

<p>注意</p> <p>下敷・ホコリ等 多量発生が有る。 インク等の液体噴射発生を防止し、 衣服を乾かす可能性が有る。 インク等の液体噴射発生が衣服に付着しないようにすること。</p>	
<p>CAUTION</p> <p> </p> <p>Do not drink the liquid under any circumstances as they can cause vomiting and diarrhea. Take care not to let the liquid come into contact with your eyes or onto your skin, otherwise inflammation can result.</p>	
<p>ACHTUNG</p> <p>Bitte trinken Sie nicht die Flüssigkeiten, da die Gefahr von Erbrechen und Durchfall besteht. Vermeiden Sie den Kontakt der Flüssigkeiten mit Augen und Haut, sonst können diese gereizt werden.</p>	
<p>ATTENTION</p> <p>No sea a beber los líquidos de ninguna manera, así como podrían causar vómitos e diarrea. Evite el contacto con los líquidos con los ojos o la piel, así como podrían causar una inflamación.</p>	
<p>ATENCIÓN</p> <p>No tome los líquidos en cualquier caso, como pueden causar vómitos y diarrea. Evite el contacto con los líquidos que estén en la piel, de otro modo inflamación puede resultar.</p>	
<p>ATTENZIONE</p> <p>Non bere per nessun motivo i liquidi poiché possono causare vomito e diarrea. Evitare il contatto di questi liquidi con gli occhi e con la pelle poiché potrebbero creare infiammazioni.</p>	
<p>CUIDADO</p> <p>No beba os líquidos sob nenhuma circunstância, pois eles podem causar vômitos e diarreia. Tome cuidado para não deixar que os líquidos entrem em contato com os olhos ou a pele, caso contrário, poderá ocorrer inflamação.</p>	

2

<p>注意</p> <p>移動中注意。 手指を近づけないこと。</p>		<p>WARNING</p> <p>Teils in Bewegung. Halten Sie Finger und andere Körperteile auf Abstand.</p>	
<p>警告</p> <p>移動中は危険です。 手指を近づけないこと。</p>		<p>AVERTISSEMENT</p> <p>Processus mobile dangereux. Éloignez les doigts et autres parties du corps.</p>	
<p>WARNING</p> <p>Hazardous moving parts. Keep fingers and other body parts away.</p>		<p>AVERTENCIA</p> <p>Partes peligrosas en movimiento. Por favor, manténgase alejado.</p>	
<p>ATENÇÃO</p> <p>Partes móveis perigosas. Mantenha as mãos e outras partes do corpo afastadas.</p>		<p>AVVERTENZA</p> <p>Attenzione parti in movimento. Tenere le dita e altre parti del corpo lontane.</p>	

3

Watch your fingers, or you may be injured.

China only

4

<p>CAUTION</p> <p>Moving plates, paper tray and covers can cause body injury. Keep hands off plates while printing.</p>	
<p>ACHTUNG</p> <p>Bewegende Platten, Papiertray und Abdeckungen können Körper- oder Verletzungen verursachen. Halten Sie die Hände von der Auflage während des Druckvorganges fern.</p>	
<p>ATTENTION</p> <p>Déplacement du plateau, chargeur, levain et couvercle peut causer le corps. Évitez les mains des plaques pendant l'impression.</p>	
<p>ATTENZIONE</p> <p> Movimento di piatti, le bandeje de papel, la cubierta pueden causar una herida personal. Evite las manos de platos durante la impresión.</p>	
<p>ATTENZIONE</p> <p>Trayente mobile, il ripiano per il Toner e i coperchi possono causare infortuni. Evitare le mani lontane dai piatti durante la stampa.</p>	
<p>警告</p> <p>フタやトレイ・紙トレイ・カバーを開閉するときは、怪我を防止するためフタやトレイを手を離してください。</p>	
<p>注意</p> <p>手袋を脱ぐ・指は指輪や指輪をはめるなど、印刷中や印刷直後は指を離してください。</p>	
<p>CUIDADO</p> <p>Movimiento de platos, bandeja de impresión y tapas pueden causar lesiones corporales.</p>	

5

<p>危険</p> <p>電圧が非常に高く、この装置をこの方法で修理すると、人身を傷める可能性があります。</p>		<p>危険</p> <p>電圧が非常に高く、この装置をこの方法で修理すると、人身を傷める可能性があります。</p>	
<p>ANGER</p> <p>High voltage is dangerous. Do not attempt to repair this device using this method. You may be injured.</p>		<p>GEFAHR</p> <p>Hochspannung ist gefährlich. Versuchen Sie nicht, dieses Gerät mit dieser Methode zu reparieren. Sie können sich verletzen.</p>	
<p>ANGER</p> <p>High voltage is dangerous. Do not attempt to repair this device using this method. You may be injured.</p>		<p>PERIGERO</p> <p>Alta tensión es peligrosa. No intente reparar este dispositivo usando este método. Puede sufrir lesiones.</p>	

6

<p>CAUTION</p> <p>Do not touch the rollers.</p>		<p>ATTENCIÓN</p> <p>No toque los rodillos.</p>	
<p>ACHTUNG</p> <p>Nicht die Walzen berühren.</p>		<p>AVERTISSEMENT</p> <p>N'effleurez pas les rouleaux.</p>	
<p>WARNING</p> <p>Do not touch the rollers.</p>		<p>AVERTENCIA</p> <p>No toque los rodillos.</p>	
<p>ATTENÇÃO</p> <p>Não toque os rolos.</p>		<p>AVVERTENZA</p> <p>Non toccare i rulli.</p>	

7



High temperature warning display

8

<p>CAUTION</p> <p>Do not drink the liquids under any circumstances, as they can cause vomiting and diarrhea. Take care not to let the liquids come into contact with your eyes or onto your skin, otherwise inflammation can result. Keep the liquids out of the reach of children.</p> <p>ATTENTION</p> <p>Ne pas avaler les liquides d'aucune manière, car ceci pourrait entraîner vomissements et diarrhée. Veillez à ne pas laisser ces liquides être en contact avec les yeux ou la peau, car ceci pourrait entraîner une inflammation. Maintenez les liquides hors de portée des enfants.</p> <p>ATTENZIONE</p> <p>Non bere per nessun motivo i liquidi poiché possono causare vomito e diarrea. Evitare il contatto di questi liquidi con gli occhi e con la pelle poiché potrebbero creare infiammazioni. Conservare i liquidi lontano dalla portata dei bambini.</p> <p>CUIDADO</p> <p>No debe ser ressum motivo i líquidos pois podem causar vômito e diarreia. Tome cuidado para não deixar que os líquidos entrem em contato com os olhos ou a pele, caso contrário, poderá ocorrer inflamação. Mantenha os líquidos fora do alcance das crianças.</p>	<p>VORSICHT</p> <p>Bitte trinken Sie nicht die Flüssigkeiten, da die Gefahr von Erbrechen und Durchfall besteht. Vermeiden Sie den Kontakt der Flüssigkeiten mit Augen und Haut, sonst können diese gereizt werden. Halten Sie die Flüssigkeiten von Kindern fern.</p> <p>ATENCIÓN</p> <p>No tome los líquidos en cualquier caso, como pueden causar vomito y diarrea. Tome el cuidado para no permitir que los líquidos toquen los ojos ni la piel, de otro modo inflamación puede resultar. Mantenga los líquidos fuera del alcance de niños.</p> <p>注意</p> <p>下痢や嘔吐する可能性があるため、インクなどの液体類をまき散らないこと、炎症を起こす可能性があるため、インクなどの液体類が目に接触したり皮膚に付いたりしないようご注意ください。子供の手の届かないところに置くこと。</p> <p>注意</p> <p>何可能導致嘔吐、泄肚、清飲效用油等液体类、有可能引发炎症。注意油类等液体类与眼睛或皮肤接触上，请放置在儿童无法触及的地方。</p> <p>注意</p> <p>■ Despecte în conformanță cu legislația europeană în vigoare. ■ Despecte în conformanță cu legislația braziliană. ■ Despecte în conformanță cu legislația turcă. ■ Despecte în conformanță cu legislația spaniolă. ■ Despecte în conformanță cu legislația franceză. ■ Despecte în conformanță cu legislația italiană. ■ Despecte în conformanță cu legislația japoneză.</p>
--	--

9

Cleaning Solution

brother

GCX-E02

TXL

ETX Series

Brother Industries, Ltd.

10

<p>CAUTION</p> <p>Do not drink the liquids under any circumstances, as they can cause vomiting and diarrhea. Take care not to let the liquids come into contact with your eyes or onto your skin, otherwise inflammation can result. Keep the liquids out of the reach of children.</p> <p>ATTENTION</p> <p>Ne pas avaler les liquides d'aucune manière, car ceci pourrait entraîner vomissements et diarrhée. Veillez à ne pas laisser ces liquides être en contact avec les yeux ou la peau, car ceci pourrait entraîner une inflammation. Maintenez les liquides hors de portée des enfants.</p>	<p>VORSICHT</p> <p>Bitte trinken Sie nicht die Flüssigkeiten, da die Gefahr von Erbrechen und Durchfall besteht. Vermeiden Sie den Kontakt der Flüssigkeiten mit Augen und Haut, sonst können diese gereizt werden. Halten Sie die Flüssigkeiten von Kindern fern.</p> <p>ATENCIÓN</p> <p>No tome los líquidos en cualquier caso, como pueden causar vomito y diarrea. Tome el cuidado para no permitir que los líquidos toquen los ojos ni la piel, de otro modo inflamación puede resultar. Mantenga los líquidos fuera del alcance de niños.</p>	<p>ATTENZIONE</p> <p>Non bere per nessun motivo i liquidi poiché possono causare vomito e diarrea. Evitare il contatto di questi liquidi con gli occhi e con la pelle poiché potrebbero creare infiammazioni. Conservare i liquidi lontano dalla portata dei bambini.</p> <p>CUIDADO</p> <p>No debe ser ressum motivo i líquidos pois podem causar vômito e diarreia. Tome cuidado para não deixar que os líquidos entrem em contato com os olhos ou a pele, caso contrário, poderá ocorrer inflamação. Mantenha os líquidos fora do alcance das crianças.</p> <p>■ Despecte în conformanță cu legislația europeană în vigoare. ■ Despecte în conformanță cu legislația braziliană. ■ Despecte în conformanță cu legislația turcă. ■ Despecte în conformanță cu legislația spaniolă. ■ Despecte în conformanță cu legislația franceză. ■ Despecte în conformanță cu legislația italiană. ■ Despecte în conformanță cu legislația japoneză.</p>	<p>注意</p> <p>下痢や嘔吐する可能性があるため、インクなどの液体類をまき散らないこと、炎症を起こす可能性があるため、インクなどの液体類が目に接触したり皮膚に付いたりしないようご注意ください。子供の手の届かないところに置くこと。</p> <p>注意</p> <p>何可能導致嘔吐、泄肚、清飲效用油等液体类、有可能引发炎症。注意油类等液体类与眼睛或皮肤接触上，请放置在儿童无法触及的地方。</p>
---	---	--	---

11

<p>brother</p> <p>グリス 油類 GREASE</p>	<p>注意</p> <p>面にべたべた塗り付くと、使用性能が低下する可能性があります。手や服を汚さないようご注意ください。</p> <p>注意</p> <p>接触による皮膚刺激、呼吸器刺激、目刺激、皮膚炎、アレルギー、皮膚腫瘍、皮膚がん、皮膚がんの原因となる可能性があります。</p>	<p>CAUTION</p> <p>Lubricating grease may cause inflammation to eyes and skin. Wear protective glasses and gloves. Swallowing grease can cause diarrhoea and vomiting. Do not swallow.</p>
--	--	--

12

<p>CAUTION</p> <p>Do not drink the liquids under any circumstances, as they can cause vomiting and diarrhea. Take care not to let the liquids come into contact with your eyes or onto your skin, otherwise inflammation can result. Keep the liquids out of the reach of children.</p> <p>ATTENTION</p> <p>Ne pas avaler les liquides d'aucune manière, car ceci pourrait entraîner vomissements et diarrhée. Veillez à ne pas laisser ces liquides être en contact avec les yeux ou la peau, car ceci pourrait entraîner une inflammation. Maintenez les liquides hors de portée des enfants.</p>	<p>VORSICHT</p> <p>Bitte trinken Sie nicht die Flüssigkeiten, da die Gefahr von Erbrechen und Durchfall besteht. Vermeiden Sie den Kontakt der Flüssigkeiten mit Augen und Haut, sonst können diese gereizt werden. Halten Sie die Flüssigkeiten von Kindern fern.</p> <p>ATENCIÓN</p> <p>No tome los líquidos en cualquier caso, como pueden causar vomito y diarrea. Tome el cuidado para no permitir que los líquidos toquen los ojos ni la piel, de otro modo inflamación puede resultar. Mantenga los líquidos fuera del alcance de niños.</p>	<p>注意</p> <p>下痢や嘔吐する可能性があるため、インクなどの液体類をまき散らないこと、炎症を起こす可能性があるため、インクなどの液体類が目に接触したり皮膚に付いたりしないようご注意ください。子供の手の届かないところに置くこと。</p> <p>注意</p> <p>何可能導致嘔吐、泄肚、清飲效用油等液体类、有可能引发炎症。注意油类等液体类与眼睛或皮肤接触上，请放置在儿童无法触及的地方。</p>
---	---	---

13

PERIGO

A tensão é perigosa e pode causar lesões. Desligar a corrente elétrica e esperar pelo menos 5 minutos antes de abrir esta tampa.

> SP <

SAFETY INSTRUCTIONS

<When you dispose of the machine>

Required Tools

Phillips screwdriver: M3 to M5

Disassembling

1) Remove the Cover PANEL SIDE.

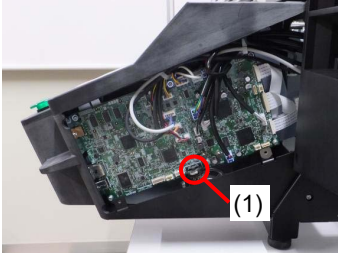

2) Remove the Lithium Battery (1) by pulling out the holder in the direction of the arrow.

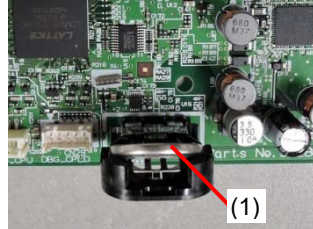
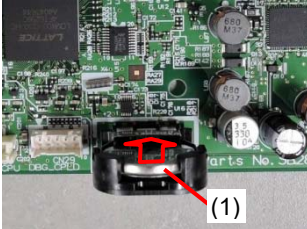

3) Pickup the Lithium Battery (1) to the direction of the arrow.



Note based on California law (USA) on the use and handling of Perchlorate

This product contains a CR Coin Lithium Battery which contains Perchlorate Material – special handling may apply.

See

<http://www.dtsc.ca.gov/hazardouswaste/perchlorate>.

Installation

1 Checking the installation site

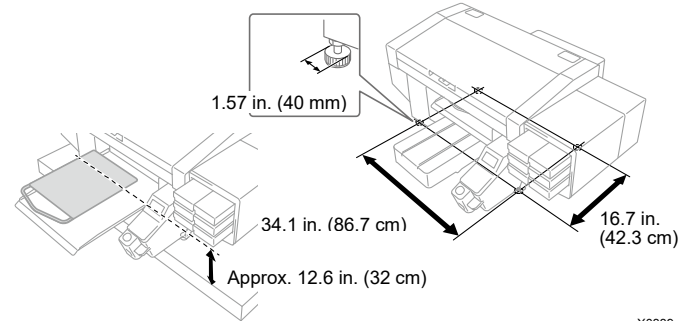
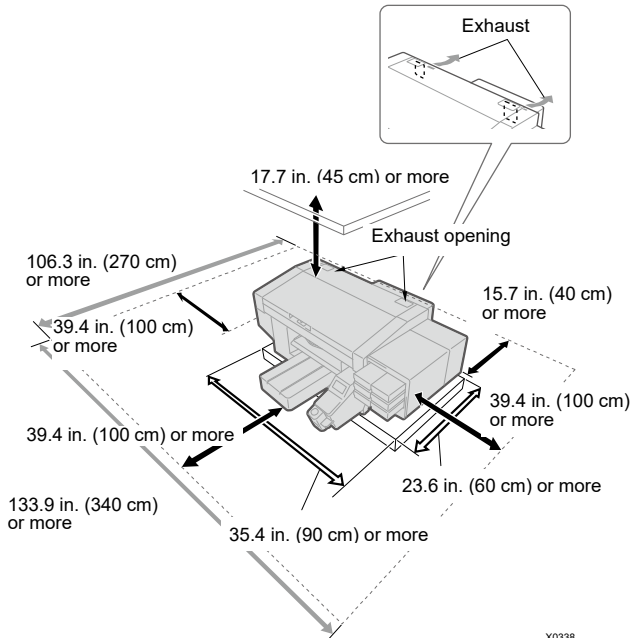

- The following environmental requirements should be met:

Environment	Temperature	Humidity
Keeping your printer	0°C (32°F) to 40°C (104°F)	20 % to 85 % (no condensation)
Working Environment *1	10°C (50°F) to 35°C (95°F)	
Recommended Print Environment *2	18°C (64.4°F) to 30°C (86°F)	35% to 85 % (no condensation)

Electrical Requirements	Power	Power Consumptions
—	Single-phase 100-240 V, 50/60 Hz	80 W

*1: Environmental range where the printer can be operated.

*2: Environmental range where sufficient printing quality can be secured.

IMPORTANT

The ink pouch for use in the initial installation should be sent in advance to the location where to install the printer and stored indoor.

*If you use ink at extremely low temperature when the outside temperature is low or in the cold season, the ink becomes hard to flow during ink installation.

- When installing the printer, avoid any place that presents direct sunlight or a large amount of dust.
- The body size is 55.1 in. (width) x 51.2 in. (depth) x 21.7 in. (height) (140 cm (width) x 130 cm (depth) x 55 cm (height)) and the mass weighs 128 kg (282 lb).
- Dimensions of the legs are 34.1 in. (86.7 cm) in width and 16.7 in. (42.3 cm) in depth. The diameter of the legs is 1.57 in. (40mm).
- The height from the table to the top surface of the platen is approx. 12.6 in. (32 cm).
- Do not use an extension cable.
- Ensure ample work space of over 39.4 in. (100 cm) in front of and to each side of the printer is available. Also, as a space to install the rear cover, keep 15.7 in. (40 cm) or wider space in the back of the printer. Keep 17.7 in. (45 cm) or wider space in the ceiling direction as well. As the air is exhausted toward the rear side, keep 7.9 in. (20 cm) or more space from the exhaust opening. If this space is not secured, you will have to move peripherals or the printer when making a repair.
- The table that supports the printer should be at least 35.4 in. (90 cm) in width and 23.6 in. (60 cm) in depth, and should be able to bear a weight of 150 kg (330 lb) or more. The tabletop should be horizontal and should not rattle when the printer is running.
- When installing the printer, place a level gauge on the top surface of the cover and the top surface of the platen to make adjustments so that the main unit is set horizontally.
- In preparation for a major earthquake or other natural disasters, fix the table and the main unit with a tool like a fixing band to prevent the main unit from falling from the table.
- When connecting the power cord of the printer, do not use overloaded sockets.

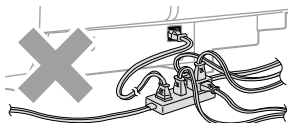

X1184

2 Unpacking

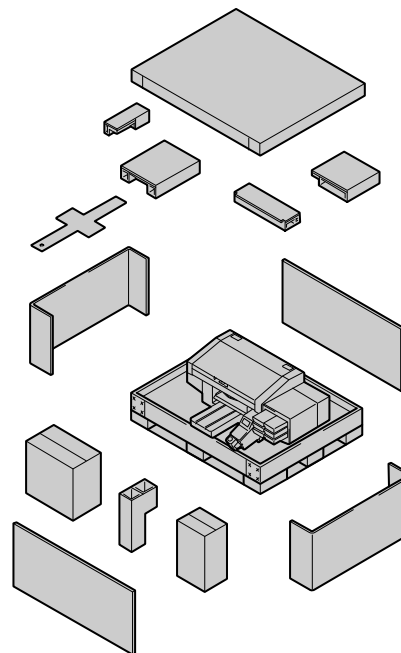

X0340

IMPORTANT

Do not turn on the power until "P.5 Removing the protection materials" is completed. Otherwise the printer may fail.

Check the supplied accessories.

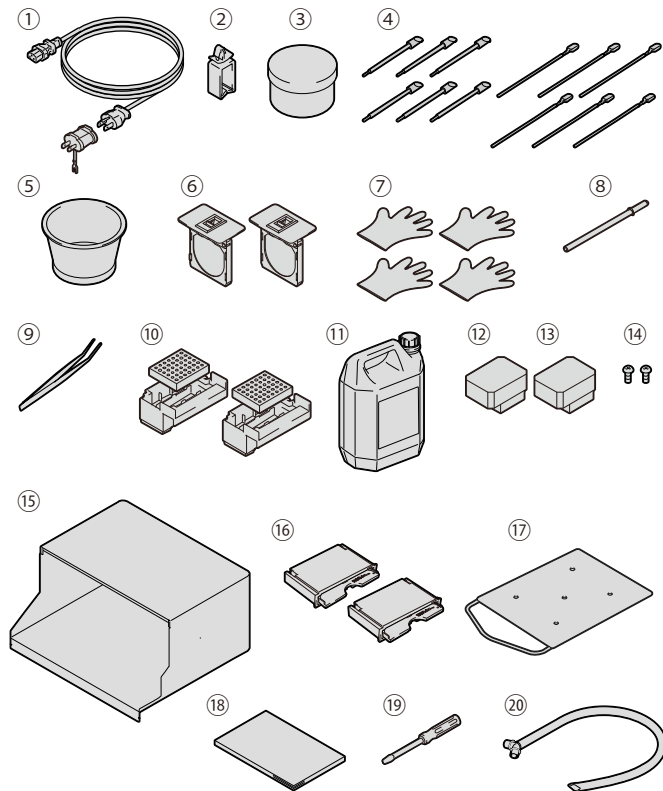

- ① AC power cord
- ② Cable clamp
- ③ Grease
- ④ Clean stick R x 6 / Clean stick T x 8
- ⑤ Cleaning cup
- ⑥ Filter cover / Fan filter x 2
- ⑦ Gloves (for changing the wiper cleaner / for cleaning the maintenance unit) x 4
- ⑧ Carriage fixing pin
- ⑨ Tweezers
- ⑩ Flushing receiver x 2 / Flushing foam x 2
- ⑪ Waste ink tank
- ⑫ Print head (for color printing)
- ⑬ Print head (for white)
- ⑭ Rear cover installation screw x 2
- * Screws are already fixed with the machine.
- ⑮ Rear cover
- ⑯ Wiper cleaner x 2
- ⑰ Adult platen
- ⑱ Setup Manual (this manual)
- ⑲ Driver
- ⑳ Waste ink tube

X0336

3 Transporting the printer

Prepare the following items along with the supplied accessories:

- Ink pouch
Black / Magenta / Cyan / Yellow x 350 ml or more (for each)
White 500 ml or more x 2
- Cleaning solution
- Pretreatment



TIPS

If you are not using white ink and using only color inks, then prepare a maintenance solution pouch instead of a white ink pouch.

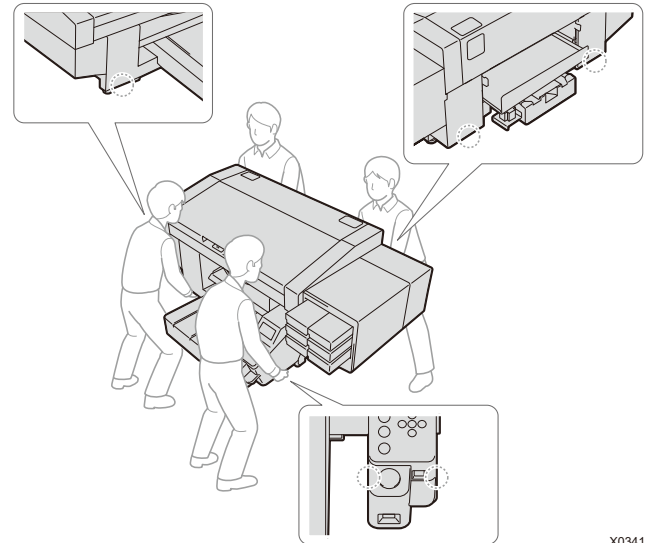

X0341



CAUTION

The printer machine weighs 128 kg (282 lb). Transporting and installing the printer requires four or more people to hold it at the ▼-marked positions (which are located where the printer can be held). Otherwise the machine may fall down, causing injury or resulting in failure of the printer.

Setup of the printer

1 Removing the protection materials

Remove all the tapes, strings and sheets shown in the below illustration.

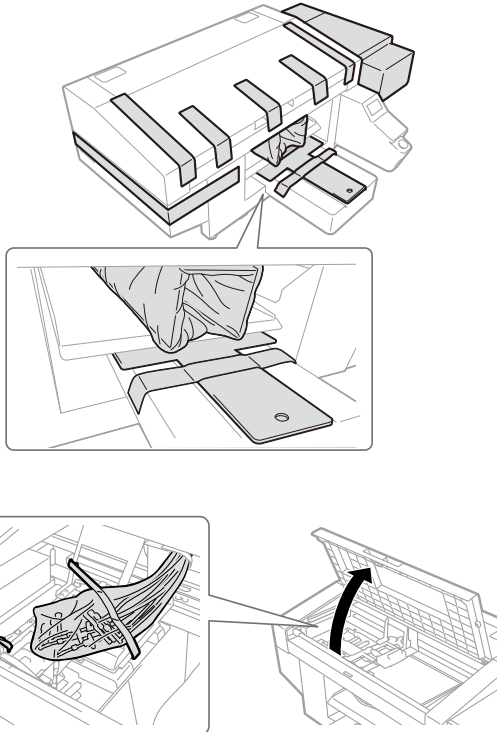

X0342

X0005

2 Mounting the supplied accessories

Mount the supplied accessories according to the following procedures.
Please note that the platen should be mounted after turning on the power.

Rear cover

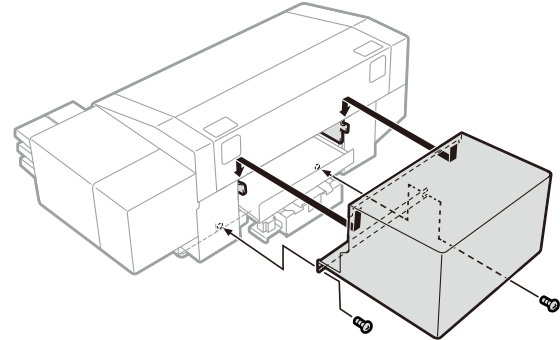

X0343

CAUTION

Be careful not to touch the claws of mounting portion on the upper side of the rear cover. Otherwise you may be injured.

Setup of the printer

Cable clamp

This is used to put the cables together.

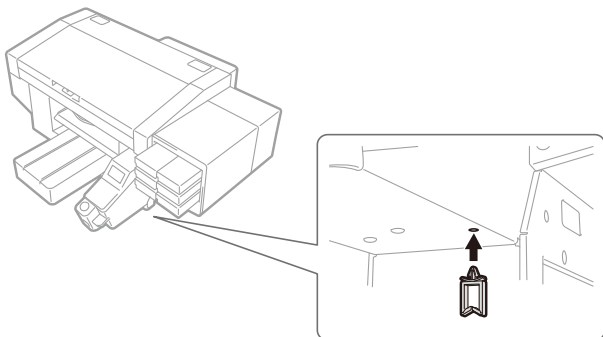

X0344

Filter cover and Fan filter

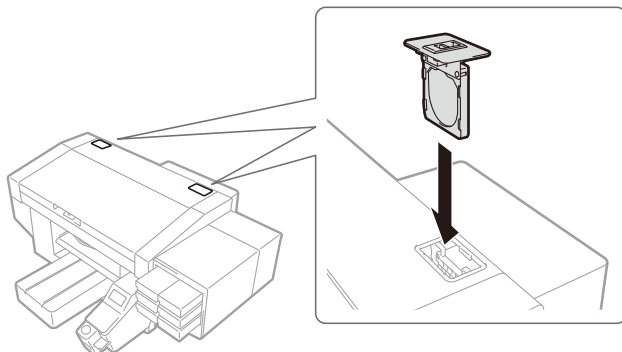

X0345

Waste ink tank

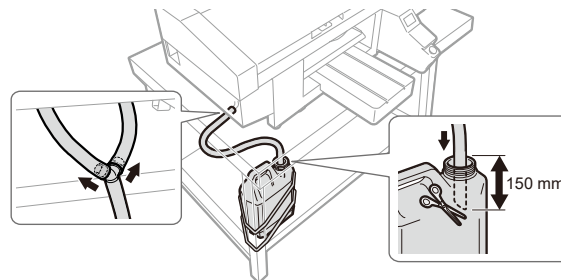

X0346

Insert the waste ink tube into the main body. Fasten the waste ink tank to the table leg or the like by using two pieces of string, etc. Insert the waste ink tube into the waste ink tank.

IMPORTANT

If the tip of the waste ink tube is immersed in the liquid, it will prevent the smooth flow of the waste ink, to disable the ink suction operation of the head cleaning function. After the waste ink tank is fastened, the waste ink tube should be cut so that the length from the tube connection is 150 mm. The waste ink tube should be cut diagonally.

Avoid placing the waste ink tube horizontally as much as possible, and be sure not to let it bend. Otherwise the waste ink may have difficulty flowing through the tube.



TIPS

Install the waste ink tank in the front, because it must be emptied when the waste ink is full.

Mount the following supplied accessories inside the printer.

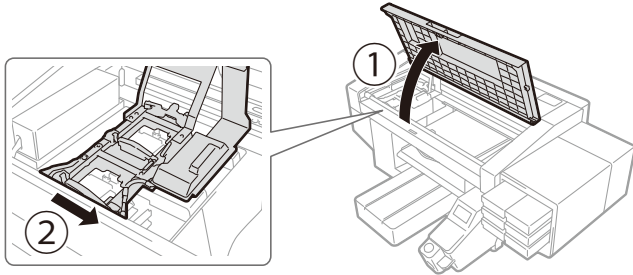

Open the cover to the direction ① and shift the carriage to direction ②. Put on the gloves that came with the printer and perform the following work.

Flushing receiver

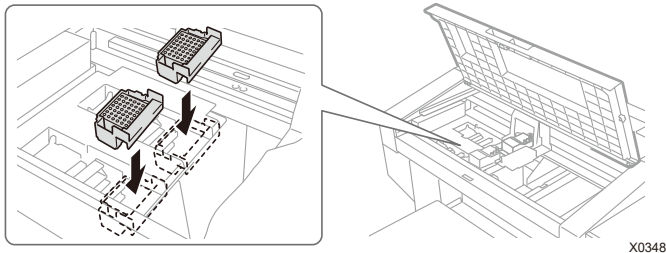

Install the printer with the hole on the bottom oriented to the front (there is no difference in white and color sides; they can be mounted on either side).

IMPORTANT

Make sure that no flushing foam extends off the outboard end portions of the flushing receiver. If it does, it may interfere with the nozzle surface of the head and may result in a problem concerning firing of the print heads.

Carriage fixing pin

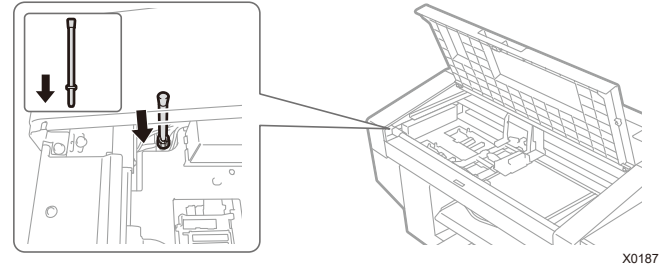

The carriage fixing pin will be needed when the power is turned OFF due to power outage while the printer is running and the recovery is not expected for a while. Secure the pin in the place illustrated above so as not to lose it.

The front cover will not close completely if the carriage is fixed with the carriage fixing pin.

Setup of the printer

Wiper cleaner

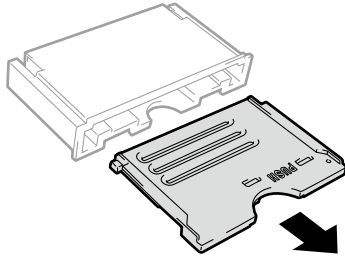

X0120



TIPS

Waste should be disposed of in accordance with regulations and laws.

Use the cleaner by expiration date written on the label. Mount it on the machine immediately after it is unpacked.

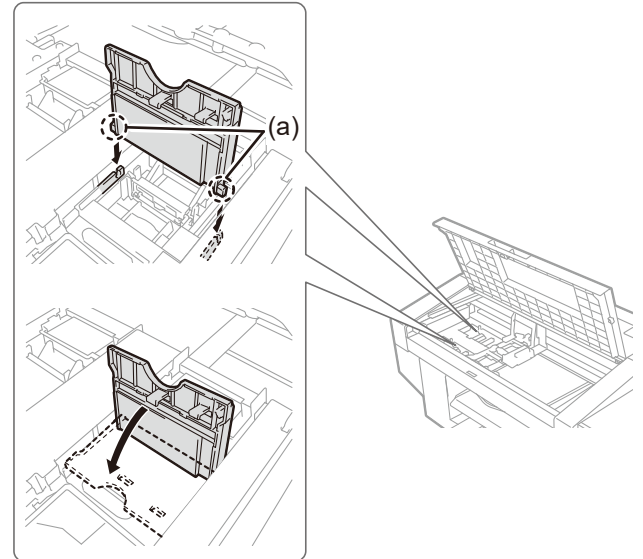

X0349

Insert the shaft (a), and push the area with the "PUSH" indication until it clicks (there is no difference in white and color sides; they can be mounted on either side).

Print head

1.

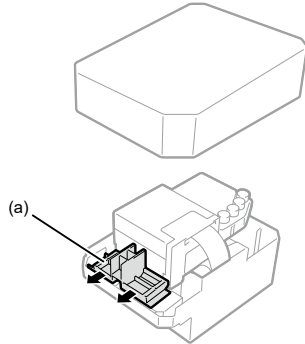

X0009

IMPORTANT

When you unpack the head, be careful not to touch the bottom of the head. Otherwise it may cause poor printing.

When you mount the head, shift the carriage toward the center of the printer; to the position above the platen. If you perform the mounting of the head when the carriage is directly above the maintenance unit, it may damage the maintenance unit or the heads.



TIPS

Do not confuse the color side print head with the white side print head. The color side (red) print head is located in front and the white side (white color) print head on the back.

The gray area (a) illustrated above may be hard and difficult to remove. If it is, use both hands to remove it.

2.

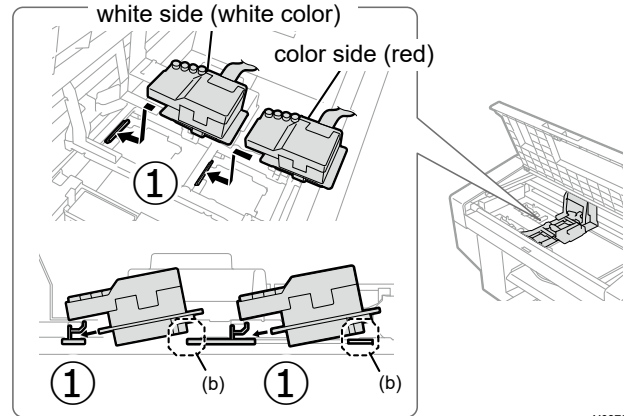

X0375

Insert the head firmly to direction ①.

IMPORTANT

If the print head is not inserted sufficiently, the part as illustrated in (b) could come into contact with its bottom surface, which in turn may result in poor printing. Make sure to insert it to the end.



CAUTION

When mounting the head, be careful not to move the carriage as much as can be avoided. Your hand may be caught in the carriage and injured. In addition, the tubes may be rolled together possibly damaging them.

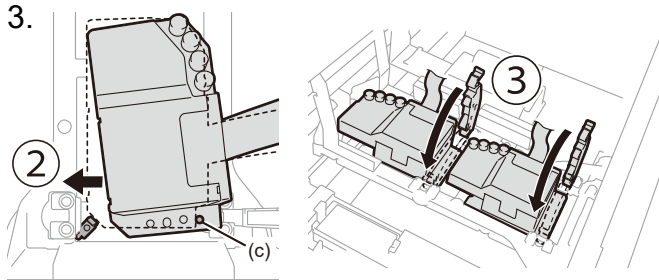

X0376

Push with force in the direction as indicated in ② so that the (c) area makes contact with the side of the metal plate of the head.



CAUTION

When you mount ③, hold it down from the top. Otherwise your finger may be pinched and injured.

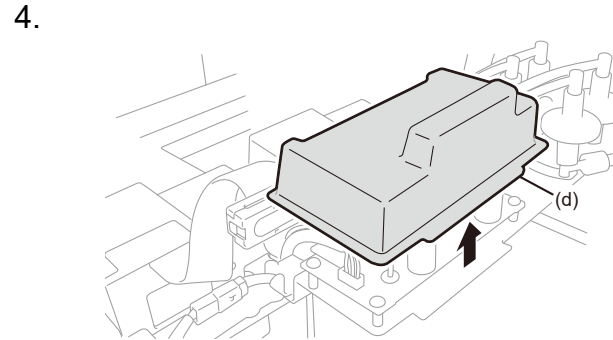

X0427

Unhook the two claws of the resin cover (d) to remove the resin cover.

5.

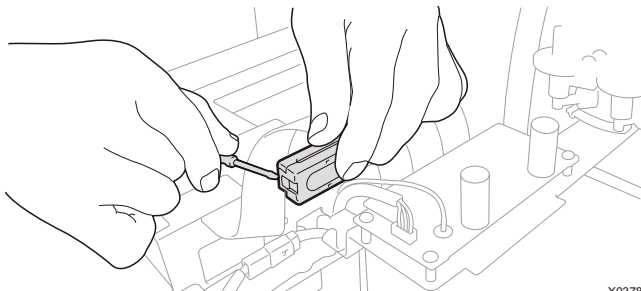

X0378

Remove the core claw using the supplied screwdriver.



Hold the core center by hand to make it easy to insert the screwdriver into the claw.

6.

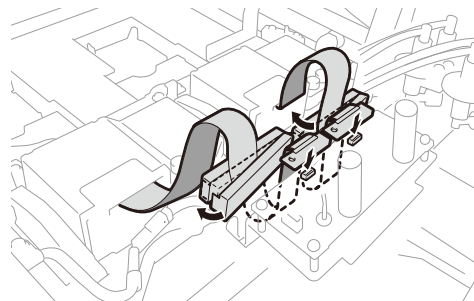

X0379

Connect the flat cable by fitting it with the core. Fit the claw by pushing the core until it clicks into place. Leave a slack to avoid interference with the resin cover.

7.

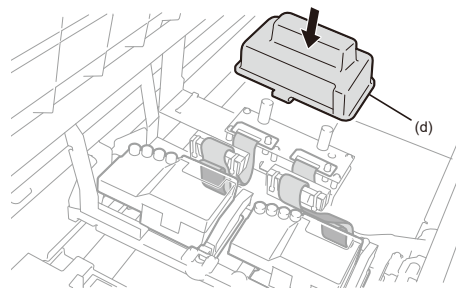

X0377

Hook the two claws of the resin cover to mount the cover (d). Tuck the extra flat cable as shown in the illustration.

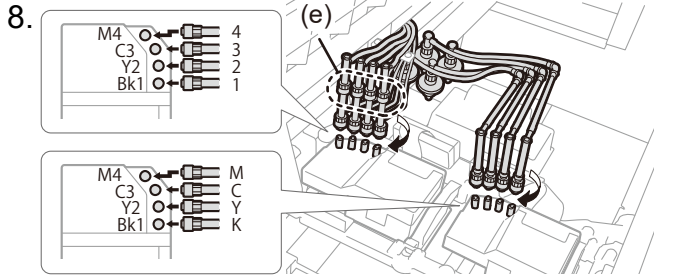

Remove four caps of the head.
Check that the head and the marker of each tube are matched and connect the tubes one by one from back to front of the machine by rotating the nut until it stops.

IMPORTANT

Do not rotate the nut as illustrated in (e). It could disconnect the tube and leak the contained ink.

Be sure to remove the caps attached to the head before connecting.

3 Filling the cleaning solution

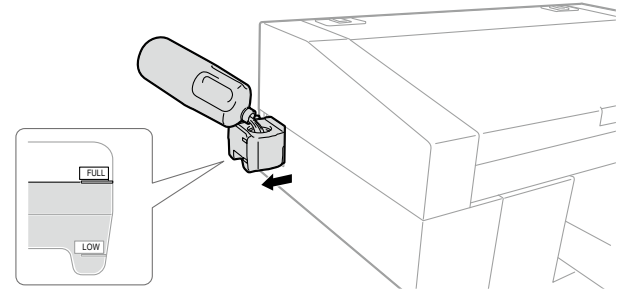

Pull out the cleaning liquid tank from the side of the printer; enough to open the lid of the tank and fill the tank with the cleaning solution until reaching the "FULL" line.
When filling is completed, close the lid and slowly push the cleaning liquid tank back inside the printer for storage.

IMPORTANT

When you pour the cleaning solution, be sure not to exceed the "FULL" line.



TIPS

After filling the cleaning solution, make sure to push the cleaning liquid tank in to the end. The cleaning liquid tank that is not properly inserted causes an error and disables printing.

4 Ink cartridge setup and installation

Install the ink pouches into cartridges by referring to the illustrations on the label located on the ink bay cover of the machine.



If you are not using white ink and using only color inks for printing, install a maintenance solution pouch instead of a white ink pouch, referring to the procedures from step 2.

1.

Since there is a component within the white ink which becomes deposited, please be sure to shake the ink pouch before it is taken out of the box.

Hold each edge of the carton containing the pouch tightly and shake it 100 times from side to side.

Next, turn it upside down and shake it 100 times.

2.

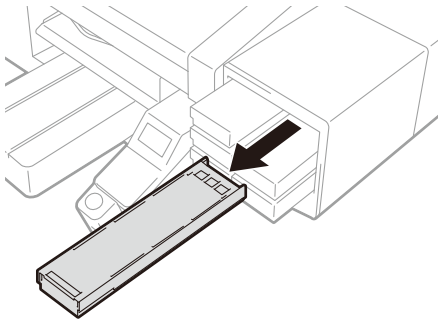

X0351

3.

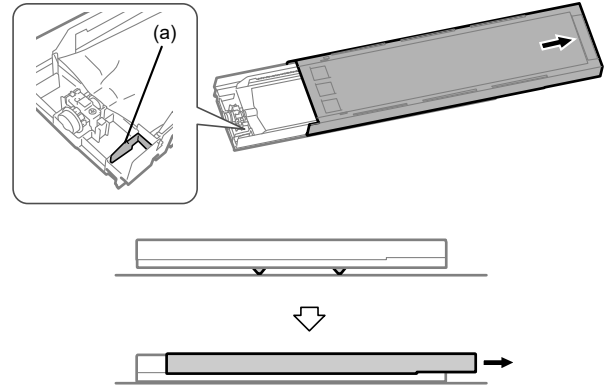

X0178

Open the lid of the ink cartridge.

IMPORTANT

When opening the lid, be sure not to touch portion (a). Otherwise, it could be damaged.

Place the entire cartridge on a flat surface, push the latches on the bottom surface of the cartridge downward and open the lid.

4.

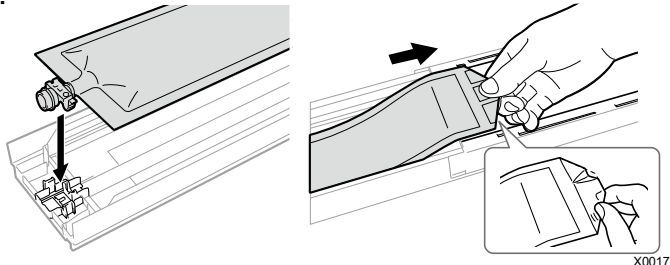

Push the tip of the ink pouch in until it clicks.
Straighten the ink pouch so that it can fit the grooves of the ink cartridge lid and mount it while pulling it by hand.



TIPS

If the edge of the ink pouch is bent or undulating significantly, make it straight with your hand.

If you are using only color inks, set a maintenance solution pouch to the position W12 and W34.

5.

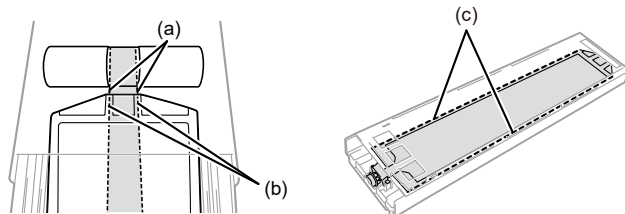

Check that the two illustrated areas (b) and (c) are straight.



CAUTION

Be careful not to touch area (a) illustrated above. Otherwise you may be injured.

5 Turning on the power

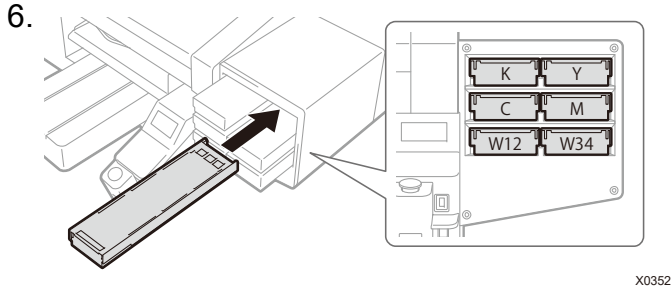

Stick the expiration date seal supplied with the ink pouch on the front side of the ink cartridge, install the cartridge in the correct color position in the machine and make sure that it is inserted into the machine until complete contact.

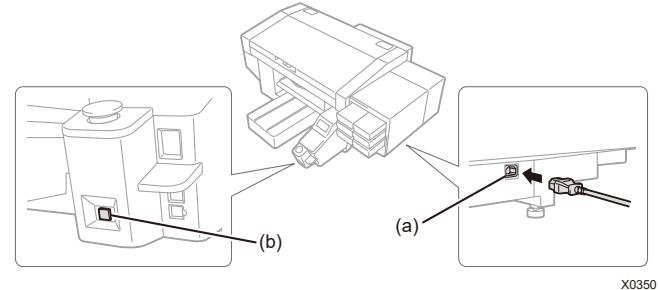

Close the cover of the machine and insert the AC power cord into (a) and the outlet. Press the power button (b) to turn the printer power ON.



TIPS

An error message "Perform Initial Ink Installation" may be displayed on the screen of the printer but it will be no problem, so please continue to perform the ink installation according to the procedures described in this manual.

6 Mounting the platen

1.

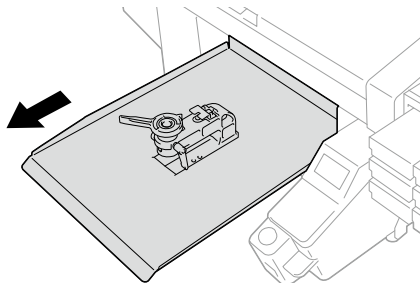

X0029

Press  on the operation panel to move the platen to the front.

2.

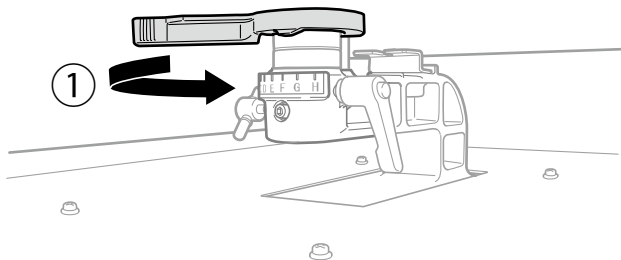

X0288

Rotate the platen height adjustment lever in direction ①, and align the scale to position "A".

3.

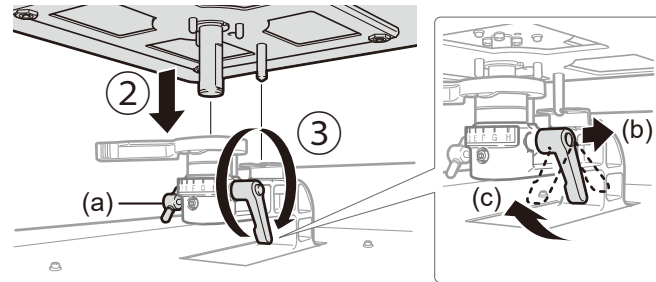

X0428

Insert the platen in direction ② and tighten the platen fixing lever in direction ③.





TIPS

Use with the knob (a) tightened when printing.

Depending on the height of the platen, the platen fixing lever may strike against the platen, and prevent rotation. In that case, move the platen fixing lever in the direction (b), draw the edge of the platen fixing lever forward as shown in (c), then loosen it again.

7 Configuring the language

Perform this operation while the printer is in Standby mode.

- 1)  -> [Language] -> Select your language -> 
- 2) Press the power button to turn off the power.

8 Installing the ink

Turn on the power of the printer and perform the operation while the printer is in Standby mode.





TIPS

If you are using only color inks, perform the following procedures.



-> [Maintenance] -> [White Ink Pause Mode] -> [Enable]
Then follow the message and perform ink installation.

- 1)  -> [Maintenance] -> [Initial Ink Installation] -> [All Print Heads]
- 2) Follow the precautions on the screen and press  (It takes about 35 minutes).
- 3) Once the system returns to the standby state, proceed to the steps of “Connecting to a PC” (on page 18).

IMPORTANT

After completing the ink installation, check the following:

- Check that the tube is filled with ink and contains no air.
- Check that the ink has reached the print head. If the above conditions are not met, proceed with the following steps:



-> [Maintenance] -> [Install Ink after Replacing Head]

Connection to a PC



Although the description of this section is based on operation with Windows, you can also use Macintosh.
For details, refer to the Instruction Manual.

1 Installing the driver

- 1) Download the ZIP file from our website and unzip the file.
- 2) Double-click on "setup.exe" -> Activate the installer
- 3) Follow the instructions on the screen.
- 4) After the installation, restart the PC.

2-A When connecting via USB

- 1) Connect the printer and PC via a USB2.0 cable.



When putting the USB cable and LAN cable together, use "P.6 Cable clamp".

- 2) Follow the instructions on the screen.



This screen may prompt more than once.
And this also may require several minutes to complete.

We recommend you to set "Brother GTX pro" or "Brother GTX pro FileOutput" as the default printer for your convenience.

2-B When connecting via LAN

Assignment of printer static IP address



The printer may not be recognized depending on your security environment. Consult the system administrator of the setting site.

The static IP address can also be set on the printer. For details, refer to the Instruction Manual.

- 1) Perform the procedures of "P.18 When connecting via USB".
- 2) Start menu -> "Brother GTX pro Tools " -> Activate " GTX pro Maintenance "
- 3) Select [Set an IP Address] -> [Next]

- 4) Select the setting method -> [Next]

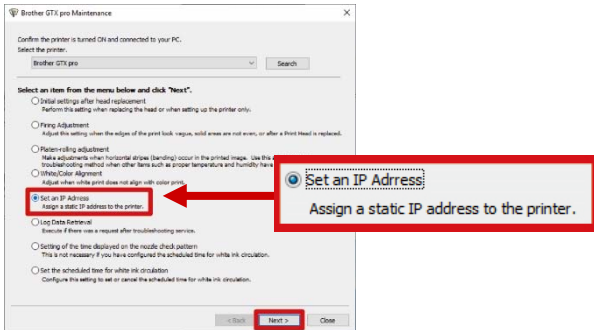
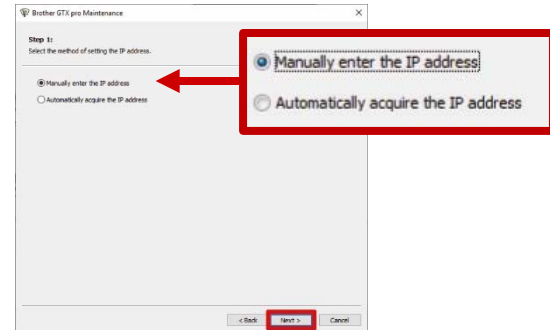

If you selected "Manually enter the IP address"

- 5) Enter the values of [IP Address][Subnet Mask][Default Gateway] -> [Next]. The steps are completed when the message [IP address was successfully assigned to the Printer.] is displayed.

Brother GTX pro Maintenance

Step 2:
Input IP address.

Input IP address, Subnet Mask and the default Gateway to the printer.

IP Address	192 . 168 . 0 . 2
Subnet Mask	255 . 255 . 255 . 0
Default Gateway	0 . 0 . 0 . 0

< Back **Next >** Cancel

If you selected "Automatically acquire the IP address"

- 5) Enter the hostname -> [Next]. The steps are completed when the message [IP address was successfully assigned to the Printer.] is displayed.

Brother GTX pro Maintenance

Step 2:
Enter the host name.

Enter the host name to be associated with the printer.

Host name : GTXpro

Press "Next" to automatically acquire the IP address.

< Back **Next >** Cancel

Installing the network print driver

- 1) Connect the printer and PC to a network using LAN cables and turn the printer power ON.
- 2) Windows 10: [Settings] -> [Devices] -> [Printers & scanners] -> click [+]
Windows 11: [Settings] -> [Bluetooth & devices] -> [Printers & scanners] -> click [Add device]

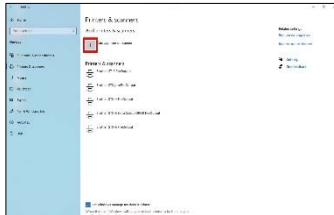

- 3) Windows 10: [The printer that I want isn't listed] -> select [Add a local printer or network printer with manual settings] -> click [Next]
Windows 11: Select [Add manually] -> click [Next]

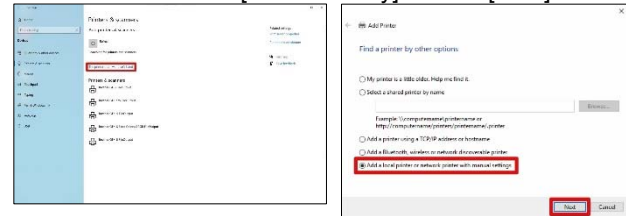

- 4) Select [Create a new port] -> From [Type of port], select [Standard TCP/IP Port] -> [Next]

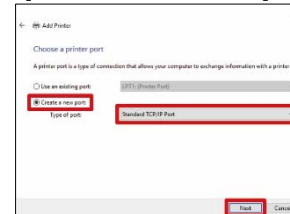

Connection to a PC

- 5) Enter the static IP address of the printer into [Hostname or IP address] -> Uncheck the check box of [Query the printer and automatically select the driver to use] -> [Next]



You can omit steps 6) through 8) if the printer driver to use is automatically selected. Follow the steps if it cannot be selected automatically.

If you set the printer's IP address by automatic acquisition, you must check the IP address of the printer in advance. You can confirm the IP address by selecting [Confirm network setting] -> [IP Address] from the menu. For details, refer to "8-25. Confirm network setting" in the Instruction Manual.

If you are using a DNS server, you can use a host name and domain name instead of the IP address. In that case, enter the host name that has been acquired automatically and set for the printer IP address (see P.20). As for the domain name, check with your network administrator.



TIPS

When the printer screen displays "00X", enter "X" in the IP address field.

- 6) From [Device Type], select [Custom] -> [Settings]

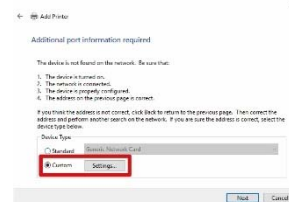

- 7) From [Protocol], select [LPR] -> Enter "BINARY_P1" in the [Queue Name] of [LPR Settings] -> [OK] -> [Next]

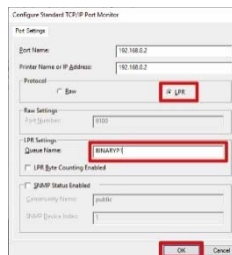

TIPS

8) From [Manufacturer], select [Brother] -> From [Printer], select [Brother GTXpro] -> [Next].

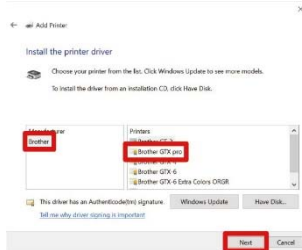

11) Select [Do not share this printer] -> [Next] -> [Finish]

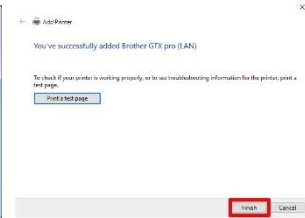
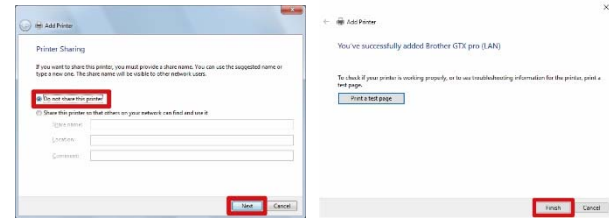

9) Select [Replace the current driver] -> [Next]

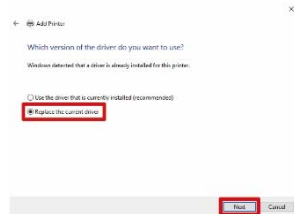

10) Enter the [Printer name] -> [Next]

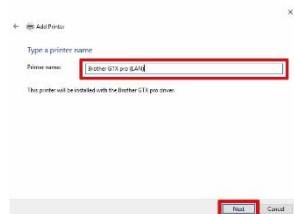

Adjustment

1 Adjusting the carriage speed

Perform the operation while the printer is in Standby mode.

1)  -> [Printer Setting] -> [CR Speed Adjustment] ->

[Start (after cleaning/setup)] ->  (It takes about 3 minutes.)

2) When the printer stops with a sound and the printer returns to Standby mode, the operation is completed.

2 Checking the nozzle check pattern

1) Make sure that the platen height adjustment lever (a) is set at the "A" position.

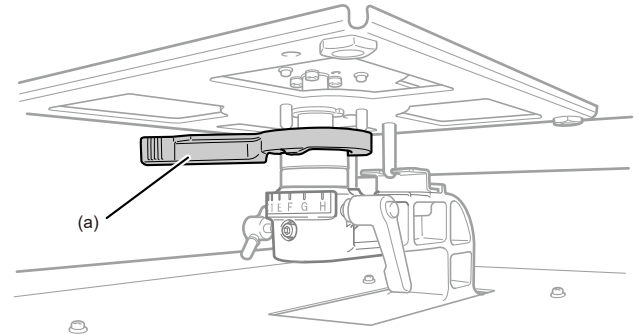

X0290



Use a platen sized 14 in. x 16 in. (356 mm x 406 mm), which is included at the time of your purchase.

- 2) Place a sheet of A4 or letter-size white paper as illustrated below (Pretreated T-shirt is also acceptable).
If the paper tends to be floated, tape the corners.

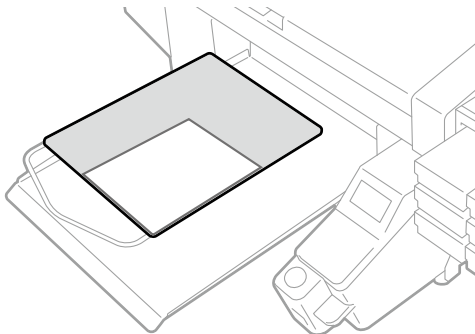

X0020

- 3) Perform the following operation on the screen of the printer:

MENU OK -> [Test Print] -> [Nozzle Check CMYK] -> **MENU OK**

- 4) When printing is finished and the printer returns to Standby mode, set a piece of black paper or transparent sheet (such as OHP sheet) of A4 or letter size in the same manner as step 2 (A pretreated black or dark color T-shirt is also acceptable).

5) **MENU OK** -> [Test Print] -> [Nozzle Check White] -> **MENU OK**

- 6) Check the printed results for both nozzle check prints and determine if there is a problem.
If missing nozzles are found as indicated by the arrows below, there is a problem concerning the firing of the print heads.

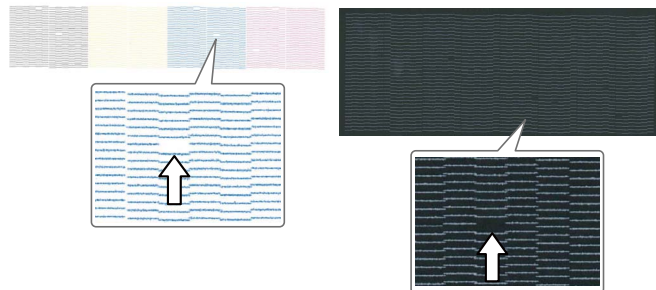

X0291



TIPS

Even if the lines of the white-side printed result are light, since white ink is fired from more than one nozzle on the same place, the quality is not affected.

- 7) If any problem is found, perform a normal cleaning.
While the printer is in Standby mode, press , select the head with the problem, and press **MENU OK**.
- 8) Check the nozzle check pattern again.
If the problem still persists, please contact your dealer.

3 Making adjustments after the print head is mounted

- 1) Connect the printer and PC via a USB 2.0 cable or LAN cable. On the PC side, "Brother GTX pro Tools" → Activate "GTX pro Maintenance".
- 2) Prepare a few sheets of A4 or letter-size paper (black paper or transparent sheet such as OHP sheet and white paper), tape for fixing the paper, and a pretreated black or dark color T-shirt.



For details for pretreatment, refer to the Instruction Manual.

- 3) Following the instructions on the "GTX pro Maintenance" screen, run the following menu options.

	Menu name	Things to prepare
1	[Initial settings after head replacement] *1	—
2	[Firing Adjustment]	Black paper or transparent sheet (such as OHP sheet) White paper
3	[Platen-Rolling Adjustment]	White paper
4	[White/Color Alignment]	Black paper or pretreated black or dark color T-shirt
5	[Setting of the time displayed on the nozzle check pattern]	—

*1: In [Initial settings after head replacement], set the values written on the print head or the container.

4 What to do in the White Ink Pause Mode

For the White ink pause mode, perform the following steps using "GTX pro Maintenance".

	Menu name	When in White Ink Pause Mode
1	[Initial settings after head replacement]	Performed for color head only Upon completion of color head setting, click [Cancel] to close the maintenance tool once and then start it. Then proceed to the following steps.
2	[Firing Adjustment]	Performed for color head only Upon completion of color head setting, click [Cancel] to close the maintenance tool once and then start it. Then proceed to the following steps.
3	[Platen-rolling adjustment]	Performed
4	[White/Color Alignment]	Not required
5	[Setting of the time displayed on the nozzle check pattern]	Performed



For information on the White ink pause mode, see "7-3. White Ink Pause Mode" in the Instruction Manual.

- 1) When the completion screen appears, click [OK] to finish the operation.



If you want to check the value you have set, do not perform the above procedures as a means to verify them. The setting will be reset and returned to the initial value. To check the value in a proper way, refer to the Instruction Manual.



Maintenance list

To maintain the printing quality and use the printer for a longer time, the following maintenance is needed.
For details, refer to the Instruction Manual.

Maintenance timing	Description	Error / Warning display
Before printing	Confirmation and disposal of waste ink	—
	Confirmation and refill of cleaning solution	○
	Daily agitation of the white ink	○
	Print out of the nozzle check pattern (checking on the print heads)	—
When an error / warning is displayed	Replacement of ink pouch with a new one	○
	Cleaning of the nozzle guard, wiper, exhaust cap and suction cap	○
	Replacing the wiper cleaner	○
	Replacing the flushing foam	○
	Replacing the fan filter	○
When the printer becomes dirty	Head cleaning	—
	White ink circulation	—
	Cleaning the CR (carriage) plate	—
	Cleaning the internal area of printer	—
	Replacing the platen sheet	—



*Please note that the contents of this manual may differ slightly from the actual product purchased as a result of product improvements.

BROTHER INDUSTRIES, LTD. <https://www.brother.com/>

1-5, Kitajizoyama, Noda-cho, Kariya 448-0803, Japan.

© 2020-2024 Brother Industries, Ltd. All Rights Reserved.

This is the original instructions.

GTX-423
SC4970-101 EN
2024.07.F(1)