

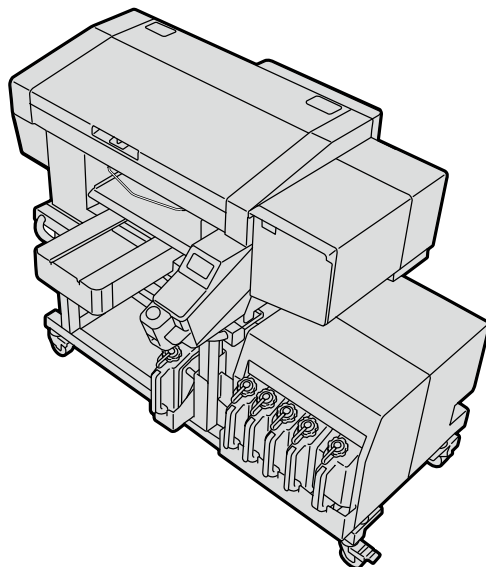

Please be sure to read this manual before using this product.
Keep this manual in a safe place for future use.







GTX pro Bulk

GARMENT PRINTER Setup Manual

Table of contents

Please be sure to read "SAFETY INSTRUCTIONS" before use.

	Installation	1
	Setup of the printer	6
	Connection to a PC	22
	Adjustment	28
	Maintenance list	31

SAFETY INSTRUCTIONS

Thank you very much for buying a BROTHER printer. Before using your new printer, please read the "SAFETY INSTRUCTIONS" and handling instructions carefully.



SAFETY INSTRUCTIONS

1. Safety indications and their meanings

This instruction manual and the indications and symbols that are used on the printer itself are provided in order to ensure safe operation of this printer and to prevent accidents and injury to yourself or other people.

The meanings of these indications and symbols are given below.

Indications

 DANGER	The instructions which follow this term indicate situations where failure to follow the instructions will result in death or serious injury.
 WARNING	The instructions which follow this term indicate situations where failure to follow the instructions could result in death or serious injury.
 CAUTION	The instructions which follow this term indicate situations where failure to follow the instructions may result in minor or moderate injury.

IMPORTANT

The instructions which follow this term indicate situations where failure to follow the instructions may result in damage to property.

NOTE

The instructions which follow this term indicate precautions and restrictions for use.

Symbols



This symbol () indicates something that you should be careful of. The picture inside the triangle indicates the nature of the caution that must be taken. (For example, the symbol at left means "beware of injury".)



This symbol () indicates something that you must not do.



This symbol () indicates something that you must do. The picture inside the circle indicates the nature of the thing that must be done. (For example, the symbol at left means "you must make a ground connection".)

2. Notes on safety

DANGER



Contact with high voltage sections may lead to a serious injury. Turn off the power, and remove the cover 5 minutes later.

WARNING

Basic precautions



To prevent accidents and problems, do not modify the machine yourself. Brother will not be held responsible for any accidents or problems resulting from modifications made to the machine.



Do not handle the power cord with wet hands. Otherwise, it may cause electric shocks.

Installation



Do not set up the printer in a dusty environment. If dust collects inside the printer, it may cause fire or electric shocks or problems with correct operation.



Be sure to connect the ground. If the ground connection is not secure, you run a high risk of receiving a serious electric shock, and problems with correct operation may also occur.



Do not bend the cords excessively or fasten them too hard with staples or anything similar to secure cords. Otherwise it may cause fire or electric shocks.



Printing



If a foreign object gets inside the printer, immediately turn off the power, disconnect the power cord, and contact the place of purchase or a qualified technician. If you continue to use the printer while there is a foreign object inside, it may result in fire or electric shocks or problems with correct operation.



Do not allow the printer to come into contact with liquids. Otherwise it may cause fire or electric shocks or problems with correct operation.











If any liquid gets inside the printer, immediately turn off the power, disconnect the power cord, and contact the place of purchase or a qualified technician.









Do not use the printer when smoke or a bad odor is coming from the printer. Otherwise it may cause fire or electric shocks or problems with correct operation. Immediately turn off the power, disconnect the power cord, and contact the place of purchase or a qualified technician.



 WARNING	
Printing	
	Keep your finger or any body part away from the rotating fan. Otherwise it will be caught up, which results in injuries. Turn off the power when you approach the fan.

 CAUTION	
Environmental requirements	
	Use the printer in a place which is adequately ventilated. A slight odor is generated when the printed articles are being fixed by heat.
Installation	
	Setting up and moving of the printer should only be carried out by a qualified technician.
	The printer machine weighs 171 kg (376 lb) (main body 128 kg (282 lb) + lower unit 43 kg (94 lb)). Transporting and setting up of the printer should be held in the proper way. Otherwise it may fall down and cause injury.
	
	When the printer falls down, disconnect the power cord and contact the place of purchase or a qualified technician. If you continue to use it, it may result in fire or electric shocks or poor printing quality.
	

	Do not place the printer on a shaky table or high shelf or other unstable location. Otherwise it may tip over or fall down and cause injury. For information on the table that supports the printer, contact the dealer.
	Do not set up the printer in a place where it will be affected by vibration. Otherwise the printing quality may be degraded or the printer may fall down, which causes injury or results in failure of the printer.
	Do not connect the power cord until installation is complete. The printer may operate if the power is turned on by mistake, which could result in injury.
	Do not climb onto the printer or place heavy objects on top of it. Otherwise it may become unbalanced and tip over or fall down and cause injury.
	Be careful not to touch the claws of the mounting portion on the upper side of the rear cover. Otherwise you may be injured.
Printing	
	This printer should only be used by operators who are appropriately trained in its safe operation.

CAUTION

Printing



Ensure there is adequate space left in front of the printer and avoid placing any objects. Otherwise your hand may get caught between the platen and an object, which may result in injury.



Do not handle the platen while printing. If your hand gets caught between the platen or the T-shirt tray and the covers, it may be injured.



Do not put your hands inside the covers while the printer's power is turned on. Otherwise your hands may touch against moving parts and this may result in injury.



When the pretreatment is applied to printed objects (like a T-shirt) with a spray or pretreatment applicator, sprayed mist is generated. So wear a pair of plastic gloves, a mask and protective glasses (or goggles) designed to shield against liquid splash, and fully take care of the air ventilation when you are working with it.



When a problem occurs with the operation of the printer, contact the place of purchase or a qualified technician.

Maintenance



Be careful not to get your fingers caught when closing the front cover, otherwise it may result in injury to your fingers.



When you mount or replace the head, be careful not to get your hands or fingers caught. Otherwise you may be injured.





Do not drink liquids such as the ink, maintenance solution, cleaning solution, pretreatment, or waste. They may cause diarrhea or vomiting. Avoid causing your eyes or skin to make contact with the ink, maintenance solution, cleaning solution, pretreatment or waste. It may cause inflammation. In case of contact with eyes, do not rub but immediately rinse the eyes with water. Keep the liquids out of the reach of children.



Be sure to wear protective goggles and gloves when handling the grease, so that it does not get into your eyes or onto your skin. It can cause inflammation. Do not drink or eat the grease. It may cause diarrhea or vomiting. Keep the liquids out of the reach of children.



CAUTION

Maintenance





-  When replacing parts and installing optional accessories, be sure to use only genuine Brother parts. Brother will not be held responsible for any accidents or problems resulting from the use of non-genuine parts.
-  When replacing parts or installing optional accessories, be sure to follow the procedures described in the Instruction Manual. Incorrect procedures could cause injuries or problems.

IMPORTANT

Printing

-  Do not move the platen by hand. Otherwise the printer may be mechanically and electrically damaged.
-  Ensure there is adequate space left in front of the printer and avoid placing any objects. The platen may be hit and damaged.

NOTE

-  Use the printer in an area which is free from sources of strong electrical noise such as electrical line noise or static electric noise. Sources of strong electrical noise may cause problems with correct operation.
-  Any fluctuations in the power supply voltage should be within $\pm 10\%$ of the rated voltage for the printer. Voltage fluctuations which are greater than this may cause problems with correct operation.
-  The power supply capacity should be greater than the requirements for the printer's power consumption. Insufficient power supply capacity may cause problems with correct operation.
-  In the event of an electrical storm, turn off the power and disconnect the power cord from the wall outlet. Lightning may cause problems with correct operation.
-  The printer is not suitable for use in places where children are present.



<About trademarks>

The names of operating systems described in the main context of this manual are abbreviated. Product names used in this manual are, in general, trademarks or registered trademarks of their respective developer or manufacture. However, in this manual, the ® marks or TM marks are not used.

Brother logo is registered trademark of Brother Industries, Ltd. Apple, Macintosh, Mac OS, iOS, OS X, macOS, Safari, iPad, iPhone, iPod and iPod touch are the trademarks or registered trademarks of Apple Inc. in the United States and other countries.

The official name of Windows® 10 is Microsoft® Windows® 10 operating system. (represented as Windows 10 in this manual)

The official name of Windows® 11 is Microsoft® Windows® 11 operating system. (represented as Windows 11 in this manual)

Microsoft®, Windows® 10, and Windows® 11 are trademarks and registered trademarks of Microsoft Corporation in the United States of America and other countries.

Other product and company names mentioned herein may be the trademarks or registered trademarks of their respective owners.

Information in this document and the specifications of this product are subject to change without notice.

<About the CE declarations>

Downloadable from: <https://www.brother.com>

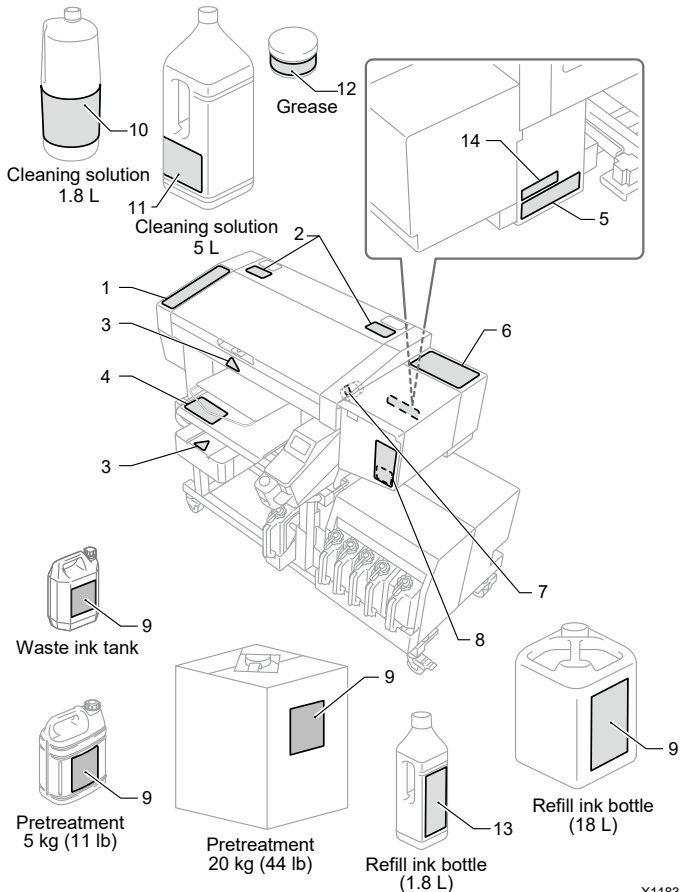

SAFETY INSTRUCTIONS

3. Warning labels



This printer has the following warning labels displayed on it. Follow the precautions given on each warning label for your work. When the label is peeled off or illegible, contact the place of purchase.

1

<p>注意</p> <p>下部から漏れが原因で発生するインクなどの液体は眼または口、皮膚などに接触してはなりません。インクなどの液体が目や皮膚に接触した場合は必ず洗浄してください。</p>	
<p>CAUTION</p> <p> </p> <p>Do not drink the liquid under any circumstances, as they can cause vomiting and diarrhea. Take care not to let the liquid come into contact with your eyes or onto your skin, otherwise inflammation can result.</p>	
<p>ACHTUNG</p> <p>Bitte trinken Sie nicht die Flüssigkeiten, da diese Erbrechen und Durchfall auslösen können. Vermeiden Sie den Kontakt der Flüssigkeiten mit Augen und Haut, sonst können diese gereizt werden.</p>	
<p>ATTENTION</p> <p>No pas a beure les liquides d'aucune manière, car cela pourrait entraîner des vomissements et de la diarrhée. Évitez de ne pas laisser ces liquides être en contact avec les yeux ou la peau, car cela pourrait entraîner une inflammation.</p>	
<p>ATENCIÓN</p> <p>No tome los líquidos en cualquier caso, como pueden causar vómitos y diarrea. Tome el cuidado para no permitir que los líquidos toquen los ojos ni en la piel.</p>	
<p>ATTENZIONE</p> <p>Non bere per nessun motivo i liquidi poiché possono causare vomito e diarrea. Evitare il contatto di questi liquidi con gli occhi o con la pelle poiché potrebbero causare infiammazioni.</p>	
<p>CUIDADO</p> <p>No beba os líquidos sob nenhuma circunstância, pois eles podem causar vômitos e diarreia. Tome cuidado para não deixar que os líquidos entrem em contato com os olhos ou a pele; caso contrário, podem ocorrer inflamações.</p>	

2

<p>警告</p> <p>目や皮膚にインクが飛びかかると、目や皮膚が刺激される可能性があります。</p>		<p>WARNING</p> <p>Take the Precaution. Ink may splash and irritate your eyes and skin.</p>	
<p>警告</p> <p>顔や皮膚にインクが飛びかかると、顔や皮膚が刺激される可能性があります。</p>		<p>AVERTISSEMENT</p> <p>Prenez les précautions. Les éclaboussures d'encre peuvent irriter votre visage et votre peau.</p>	
<p>WARNING</p> <p>Hazardous moving parts. Keep fingers and other body parts away.</p>		<p>ADVERTENCIA</p> <p>Partes peligrosas en movimiento. Por favor, manténgase alejado de ellas.</p>	
<p>ATENÇÃO</p> <p>Podem haver partes móveis. Mantenha os dedos e outras partes do corpo afastadas.</p>		<p>AVVERTENZA</p> <p>Attenzione parti in movimento. Tenga le dita e altre parti del corpo lontane.</p>	

3



Watch your fingers, or you may be injured.

China only

4

<p>CAUTION</p> <p>Mounting, battery and covers are connected with sharp edges or sharp wire points.</p>	
<p>ACHTUNG</p> <p>Die Bauteile, die Batterie und Abdeckungen können scharfe Kanten oder scharfe Drahtspitzen verursachen. Halten Sie die Finger von den Bauteilen während des Druckerbaus fern.</p>	
<p>ATTENTION</p> <p>Travailler ou débrancher, charger l'énergie et couvrir peut blesser le corps. Garder les mains éloignées des bords tranchants.</p>	
<p>ATTENZIONE</p> <p>Movendo le dita, la batteria e i coperchi di plastica possono causare una ferita personale. Tenere le mani lontane dai bordi taglienti.</p>	
<p>CUIDADO</p> <p>Moviendo los dedos, la batería y las tapas pueden causar una herida personal. Tenere las manos alejadas de los bordes cortantes.</p>	

5

<p>危険</p> <p>危険な部品があります。怪我の原因となる可能性があります。</p>	<p>危險</p> <p>危險な部品があります。受傷の原因となる可能性があります。</p>
<p>DANGER</p> <p>Caution: Hazardous parts. Injury may occur.</p>	<p>GEFAHR</p> <p>Warnung: Gefahrliche Teile. Verletzungen können eintreten.</p>
<p>ATTENZIONE</p> <p>Attenzione: Parti pericolose. Lesioni possono verificarsi.</p>	<p>PERIGLO</p> <p>Atenção: Partes perigosas. Podem ocorrer lesões.</p>

6

<p>CAUTION</p> <p>Do not touch the printer's internal parts.</p>		<p>ATTENZIONE</p> <p>Non toccare le parti interne della stampante.</p>	
<p>ACHTUNG</p> <p>Bitte nicht an die internen Bauteile der Drucker drücken.</p>		<p>ATTENZIONE</p> <p>Non toccare le parti interne della stampante.</p>	
<p>ATTENTION</p> <p>Do not touch the printer's internal parts.</p>		<p>ATTENZIONE</p> <p>Non toccare le parti interne della stampante.</p>	
<p>CUIDADO</p> <p>No toque las partes internas de la impresora.</p>		<p>ATTENZIONE</p> <p>Non toccare le parti interne della stampante.</p>	



7



High temperature warning display

8

⚠ CAUTION	
	
Take care not to let the liquids come into contact with your eyes or onto your skin, otherwise inflammation can result.	
⚠ ACHTUNG	
Vermeiden Sie den Kontakt der Flüssigkeiten mit Augen und Haut, sonst können diese gerizet werden.	
⚠ ATTENTION	
Veuillez à ne pas laisser ces liquides être en contact avec les yeux ou la peau, car ceci pourrait entraîner une inflammation.	
⚠ ATENCIÓN	
Tome el cuidado para no permitir que los líquidos toquen los ojos ni la piel, de otro modo inflamación puede resultar.	
⚠ ATTENZIONE	
Evitare il contatto di questi liquidi con gli occhi e con la pelle poiché potrebbero creare infiammazioni.	
⚠ 注意	
インクなど、液体類が目に飛び散る可能性があります。インクなどの液体類が目や皮膚に付かないようご注意ください。	
⚠ CUIDADO	
Tome cuidado para não deixar que os líquidos entrem em contato com os olhos ou a pele, caso contrário, poderá ocorrer inflamação.	

⚠ 注意	
	
有可能引发炎症。 注意油墨等液体类不要飞溅到眼中或皮肤上。	

China only

10

Brother Solution Brother Solutions Group 20000 Parkway Blvd. Irvine, CA 92618-1697 USA Tel: 949.471.2000 Fax: 949.471.2001 Email: brother@brother.com Website: www.brother.com © 2010 Brother International Corporation All rights reserved.		brother Brother International Corporation GCX-AE02 Brother 20000 Parkway Blvd. Irvine, CA 92618-1697 USA Tel: 949.471.2000 Fax: 949.471.2001 Email: brother@brother.com Website: www.brother.com © 2010 Brother International Corporation All rights reserved.		⚠ CAUTION Do not use the liquid under any circumstances, as they can cause vomiting and diarrhea. ⚠ ATTENTION Ne pas utiliser les liquides d'aucune manière, car ceci pourrait entraîner vomissements et diarrhée. ⚠ ATENCIÓN No tome los líquidos en cualquier caso, como pueden causar vómitos y diarrea. ⚠ ATTENZIONE Non bere per nessun motivo i liquidi poiché possono causare vomito e diarrea. ⚠ 注意 何れも飲まずに、液体類を吐き出す、下痢の原因となる可能性があります。		⚠ VORSICHT Bitte trinken Sie nicht die Flüssigkeiten, da die Gefahr von Erbrechen und Durchfall besteht. ⚠ ATTENÇÃO Não beba os líquidos sob nenhuma circunstância, pois eles podem causar vômito e diarreia. ⚠ ATTENZIONE Non bere per nessun motivo i liquidi poiché possono causare vomito e diarrea. ⚠ 注意 何れも飲まずに、液体類を吐き出す、下痢の原因となる可能性があります。	
⚠ ATTENTION Take care not to let the liquids come into contact with your eyes or onto your skin, otherwise inflammation can result.		⚠ ATTENTION Take care not to let the liquids come into contact with your eyes or onto your skin, otherwise inflammation can result.		⚠ ATTENTION Take care not to let the liquids come into contact with your eyes or onto your skin, otherwise inflammation can result.		⚠ ATTENTION Take care not to let the liquids come into contact with your eyes or onto your skin, otherwise inflammation can result.	
⚠ ATTENTION Veuillez à ne pas laisser ces liquides être en contact avec les yeux ou la peau, car ceci pourrait entraîner une inflammation.		⚠ ATTENTION Veuillez à ne pas laisser ces liquides être en contact avec les yeux ou la peau, car ceci pourrait entraîner une inflammation.		⚠ ATTENTION Veuillez à ne pas laisser ces liquides être en contact avec les yeux ou la peau, car ceci pourrait entraîner une inflammation.		⚠ ATTENTION Veuillez à ne pas laisser ces liquides être en contact avec les yeux ou la peau, car ceci pourrait entraîner une inflammation.	
⚠ ATENCIÓN Tome el cuidado para no permitir que los líquidos toquen los ojos ni la piel, de otro modo inflamación puede resultar.		⚠ ATENCIÓN Tome el cuidado para no permitir que los líquidos toquen los ojos ni la piel, de otro modo inflamación puede resultar.		⚠ ATENCIÓN Tome el cuidado para no permitir que los líquidos toquen los ojos ni la piel, de otro modo inflamación puede resultar.		⚠ ATENCIÓN Tome el cuidado para no permitir que los líquidos toquen los ojos ni la piel, de otro modo inflamación puede resultar.	
⚠ ATTENZIONE Evitare il contatto di questi liquidi con gli occhi e con la pelle poiché potrebbero creare infiammazioni.		⚠ ATTENZIONE Evitare il contatto di questi liquidi con gli occhi e con la pelle poiché potrebbero creare infiammazioni.		⚠ ATTENZIONE Evitare il contatto di questi liquidi con gli occhi e con la pelle poiché potrebbero creare infiammazioni.		⚠ ATTENZIONE Evitare il contatto di questi liquidi con gli occhi e con la pelle poiché potrebbero creare infiammazioni.	
⚠ 注意 インクなど、液体類が目に飛び散る可能性があります。インクなどの液体類が目や皮膚に付かないようご注意ください。		⚠ 注意 インクなど、液体類が目に飛び散る可能性があります。インクなどの液体類が目や皮膚に付かないようご注意ください。		⚠ 注意 インクなど、液体類が目に飛び散る可能性があります。インクなどの液体類が目や皮膚に付かないようご注意ください。		⚠ 注意 インクなど、液体類が目に飛び散る可能性があります。インクなどの液体類が目や皮膚に付かないようご注意ください。	
⚠ CUIDADO Tome cuidado para não deixar que os líquidos entrem em contato com os olhos ou a pele, caso contrário, poderá ocorrer inflamação.		⚠ CUIDADO Tome cuidado para não deixar que os líquidos entrem em contato com os olhos ou a pele, caso contrário, poderá ocorrer inflamação.		⚠ CUIDADO Tome cuidado para não deixar que os líquidos entrem em contato com os olhos ou a pele, caso contrário, poderá ocorrer inflamação.		⚠ CUIDADO Tome cuidado para não deixar que os líquidos entrem em contato com os olhos ou a pele, caso contrário, poderá ocorrer inflamação.	

11

⚠ CAUTION Do not drink the liquid under any circumstances, as they can cause vomiting and diarrhea. ⚠ ATTENTION Ne pas utiliser les liquides d'aucune manière, car ceci pourrait entraîner vomissements et diarrhée. ⚠ ATENCIÓN No tome los líquidos en cualquier caso, como pueden causar vómitos y diarrea. ⚠ ATTENZIONE Non bere per nessun motivo i liquidi poiché possono causare vomito e diarrea. ⚠ 注意 何れも飲まずに、液体類を吐き出す、下痢の原因となる可能性があります。		⚠ VORSICHT Bitte trinken Sie nicht die Flüssigkeiten, da die Gefahr von Erbrechen und Durchfall besteht. ⚠ ATTENÇÃO Não beba os líquidos sob nenhuma circunstância, pois eles podem causar vômito e diarreia. ⚠ ATTENZIONE Non bere per nessun motivo i liquidi poiché possono causare vomito e diarrea. ⚠ 注意 何れも飲まずに、液体類を吐き出す、下痢の原因となる可能性があります。		⚠ ATTENZIONE Non bere per nessun motivo i liquidi poiché possono causare vomito e diarrea. ⚠ ATTENZIONE Non bere per nessun motivo i liquidi poiché possono causare vomito e diarrea. ⚠ ATTENZIONE Non bere per nessun motivo i liquidi poiché possono causare vomito e diarrea. ⚠ ATTENZIONE Non bere per nessun motivo i liquidi poiché possono causare vomito e diarrea.		⚠ 注意 下痢、おう吐する可能性がある。インクなどの液体類を吐き出すこと、下痢を原因とする可能性があります。インクなどの液体類が目に飛び散る可能性があります。インクなどの液体類が目や皮膚に付かないようご注意ください。	
--	--	---	--	--	--	--	--

12

brother グリース GREASE		⚠ 注意 潤滑剤入りで油質がつく、皮膚を乾かすこと、油質が乾くと、手袋を脱ぐと、皮膚が乾く、手袋を脱ぐと、皮膚が乾く、手袋を脱ぐと、皮膚が乾く。		⚠ 注意 加減した状態で使用しないで、過度に使用しないで、過度に使用しないで、過度に使用しないで。		⚠ CAUTION Lubricating grease may cause inflammation to eyes and skin. Wear protective glasses and gloves. Swallowing grease can cause diarrhoea and vomiting. Do not swallow.	
----------------------------------	--	--	--	---	--	--	--

9

⚠ CAUTION		⚠ VORSICHT	
			
Do not drink the liquids under any circumstances, as they can cause vomiting and diarrhea.		Bitte trinken Sie nicht die Flüssigkeiten, da die Gefahr von Erbrechen und Durchfall besteht.	
Take care not to let the liquids come into contact with your eyes or onto your skin, otherwise inflammation can result.		Vermeiden Sie den Kontakt der Flüssigkeiten mit Augen und Haut, sonst können diese gerizet werden.	
⚠ ATTENTION		⚠ ATTENÇÃO	
Ne pas utiliser les liquides d'aucune manière, car ceci pourrait entraîner vomissements et diarrhée.		Não beba os líquidos sob nenhuma circunstância, pois eles podem causar vômito e diarreia.	
Veuillez à ne pas laisser ces liquides être en contact avec les yeux ou la peau, car ceci pourrait entraîner une inflammation.		Veuillez à ne pas laisser ces liquides être en contact avec les yeux ou la peau, car ceci pourrait entraîner une inflammation.	
⚠ ATENCIÓN		⚠ ATTENZIONE	
Tome el cuidado para no permitir que los líquidos toquen los ojos ni la piel, de otro modo inflamación puede resultar.		Non bere per nessun motivo i liquidi poiché possono causare vomito e diarrea.	
Evitare il contatto di questi liquidi con gli occhi e con la pelle poiché potrebbero creare infiammazioni.		Evitare il contatto di questi liquidi con gli occhi e con la pelle poiché potrebbero creare infiammazioni.	
⚠ 注意		⚠ 注意	
インクなど、液体類が目に飛び散る可能性があります。インクなどの液体類が目や皮膚に付かないようご注意ください。		インクなど、液体類が目に飛び散る可能性があります。インクなどの液体類が目や皮膚に付かないようご注意ください。	
⚠ CUIDADO		⚠ 注意	
Tome cuidado para não deixar que os líquidos entrem em contato com os olhos ou a pele, caso contrário, poderá ocorrer inflamação.		インクなど、液体類が目に飛び散る可能性があります。インクなどの液体類が目や皮膚に付かないようご注意ください。	

13

⚠ CAUTION	
	
Do not drink the liquid under any circumstances, as they can cause vomiting and diarrhea.	
Take care not to let the liquids come into contact with your eyes or onto your skin, otherwise inflammation can result.	
⚠ VORSICHT	
Bitte trinken Sie nicht die Flüssigkeiten, da die Gefahr von Erbrechen und Durchfall besteht.	
Vermeiden Sie den Kontakt der Flüssigkeiten mit Augen und Haut, sonst können diese gerizet werden.	
⚠ ATTENTION	
Ne pas utiliser les liquides d'aucune manière, car ceci pourrait entraîner vomissements et diarrhée.	
Veuillez à ne pas laisser ces liquides être en contact avec les yeux ou la peau, car ceci pourrait entraîner une inflammation.	
⚠ ATENCIÓN	
Tome el cuidado para no permitir que los líquidos toquen los ojos ni la piel, de otro modo inflamación puede resultar.	
Evitar el contacto de estos líquidos con los ojos y con la piel, ya que podrían crear inflamaciones.	
⚠ ATTENZIONE	
Non bere per nessun motivo i liquidi poiché possono causare vomito e diarrea.	
Evitare il contatto di questi liquidi con gli occhi e con la pelle poiché potrebbero creare infiammazioni.	
⚠ CUIDADO	
Não beba por nenhum motivo i líquidos pois podem causar vômito e diarreia.	
Evitar o contato de estes líquidos com os olhos e com a pele, pois eles podem causar inflamações.	
⚠ 注意	
インクなど、液体類が目に飛び散る可能性があります。インクなどの液体類が目や皮膚に付かないようご注意ください。	
⚠ 注意	
インクなど、液体類が目に飛び散る可能性があります。インクなどの液体類が目や皮膚に付かないようご注意ください。	

14

		⚠ PERIGO	
A tensão é perigosa e pode causar lesões.		A tensão é perigosa e pode causar lesões.	
Evitar a corrente elétrica e esperar pelo menos 5 minutos antes de abrir esta lâmpada.		Evitar a corrente elétrica e esperar pelo menos 5 minutos antes de abrir esta lâmpada.	

SAFETY INSTRUCTIONS

<When you dispose of the machine>

Required Tools

Phillips screwdriver: M3 to M5

Disassembling

1) Remove the Cover PANEL SIDE.

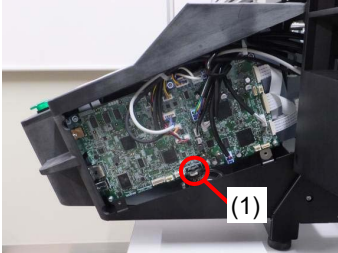

2) Remove the Lithium Battery (1) by pulling out the holder in the direction of the arrow.

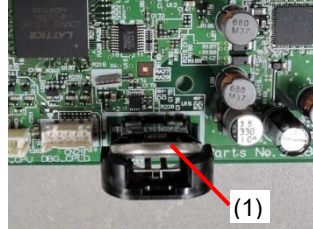
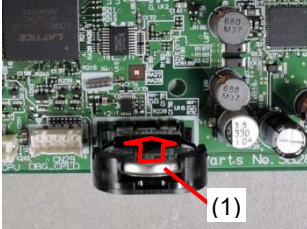

3) Pickup the Lithium Battery (1) to the direction of the arrow.



Note based on California law (USA) on the use and handling of Perchlorate

This product contains a CR Coin Lithium Battery which contains Perchlorate Material – special handling may apply.
See

<http://www.dtsc.ca.gov/hazardouswaste/perchlorate>.

Installation

1 Checking the installation site

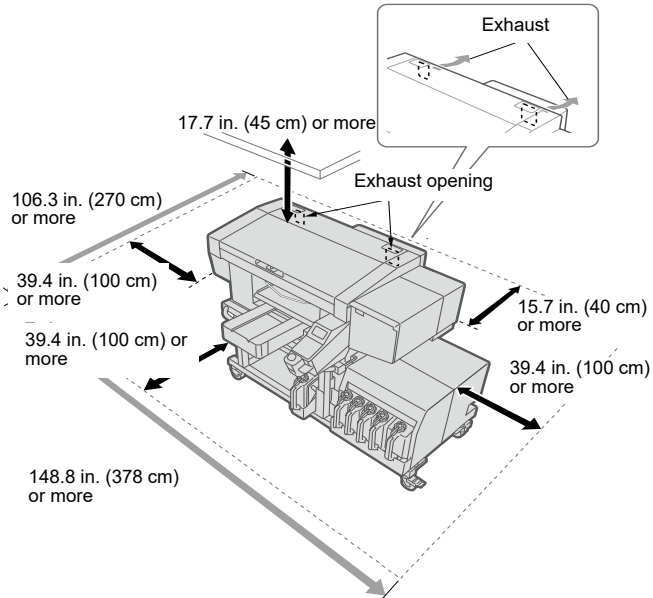

X0355

IMPORTANT

The ink pouch for use in the initial installation should be sent in advance to the location where to install the printer and stored indoor.
 *If you use ink at extremely low temperature when the outside temperature is low or in the cold season, the ink becomes hard to flow during ink installation.

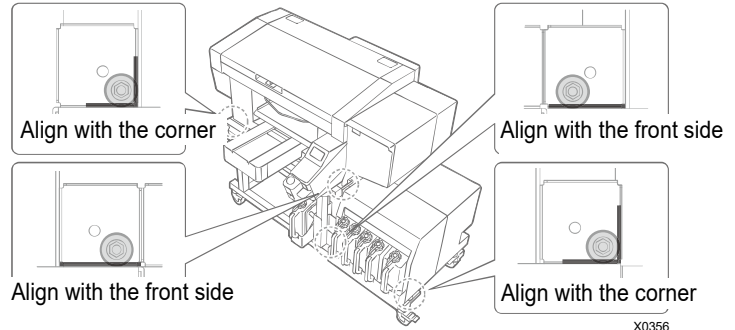

X0356

- The following environmental requirements should be met:

Environment	Temperature	Humidity
Keeping your printer	0°C (32°F) to 40°C (104°F)	20 % to 85 % (no condensation)
Working Environment *1	10°C (50°F) to 35°C (95°F)	
Recommended Print Environment *2	18°C (64.4°F) to 30°C (86°F)	35% to 85 % (no condensation)

Electrical Requirements	Power	Power Consumptions
—	Single-phase 100-240 V, 50/60 Hz	160 W

*1: Environmental range where the printer can be operated.

*2: Environmental range where sufficient printing quality can be secured.

2 Unpacking

- When installing the printer, avoid any place that presents direct sunlight or a large amount of dust.
- The body size is 70 in. (width) x 51.2 in. (depth) x 47.6 in. (height) (178 cm (width) x 130 cm (depth) x 121 cm (height)) and the mass weighs 171 kg (377 lb).
- Do not use an extension cable.
- Ensure ample work space of over 39.4 in. (100 cm) in front of and to each side of the printer is available. Also, as a space to install the rear cover, keep 15.7 in. (40 cm) or wider space in the back of the printer. Keep 17.7 in. (45 cm) or wider space in the ceiling direction as well. As the air is exhausted toward the rear side, keep 7.9 in. (20 cm) or more space from the exhaust opening. If this space is not secured, you will have to move peripherals or the printer when making a repair.
- When installing the printer, place a level gauge on the top surface of the cover and the top surface of the platen to make adjustments so that the main unit is set horizontally.
- In preparation for a major earthquake or other natural disasters, fix the table and the main unit with a tool like a fixing band to prevent the main unit from falling from the table.
- Place the tank unit on the table and align the main body and tank unit front legs with the frame corner.
- When connecting the power cord of the printer, do not use overloaded sockets.

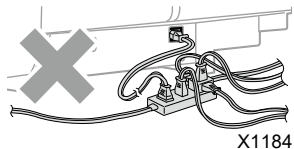

X1184

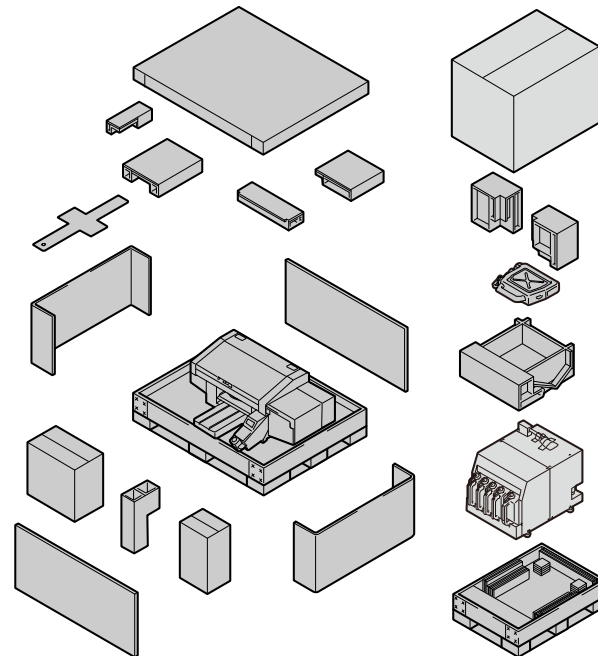

X0381

IMPORTANT

Do not turn on the power until "P.6 Removing the protection materials" is completed. Otherwise the printer may fail.

Check the supplied accessories.

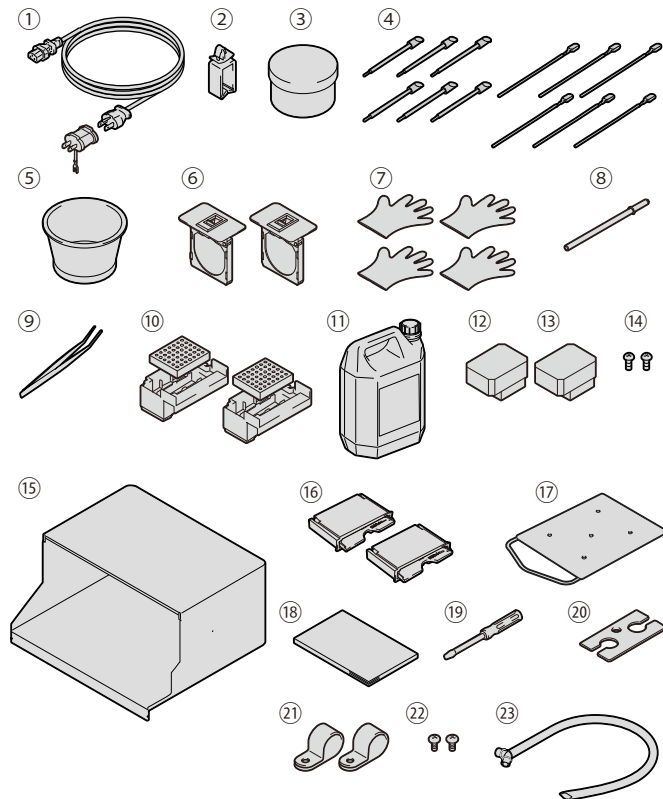

- ① AC power cord
- ② Cable clamp
- ③ Grease
- ④ Clean stick R x 6 / Clean stick T x 6
- ⑤ Cleaning cup
- ⑥ Filter cover / Fan filter x 2
- ⑦ Gloves (for changing the wiper cleaner / for cleaning the maintenance unit) x 4
- ⑧ Carriage fixing pin
- ⑨ Tweezers
- ⑩ Flushing receiver x 2 / Flushing foam x 2
- ⑪ Waste ink tank
- ⑫ Print head (for color printing)
- ⑬ Print head (for white)
- ⑭ Rear cover installation screw x 2
- * Screws are already fixed with the machine.
- ⑮ Rear cover
- ⑯ Wiper cleaner x 2
- ⑰ Adult platen
- ⑱ Setup Manual (this manual)
- ⑲ Driver
- ⑳ Connector cover
- ㉑ Cord holder x 2
- ㉒ Cord holder installation screw x 2
- ㉓ Waste ink tube

X0432

Installation

Prepare the following items along with the supplied accessories:

- Refill ink bottle
 - Black / Magenta / Cyan / Yellow 1.8 L x 2 or 18 L x 1 (for each)
 - White 1.8 L x 3 or 18 L x 1
- Cleaning solution
- Pretreatment

3 Transporting the printer

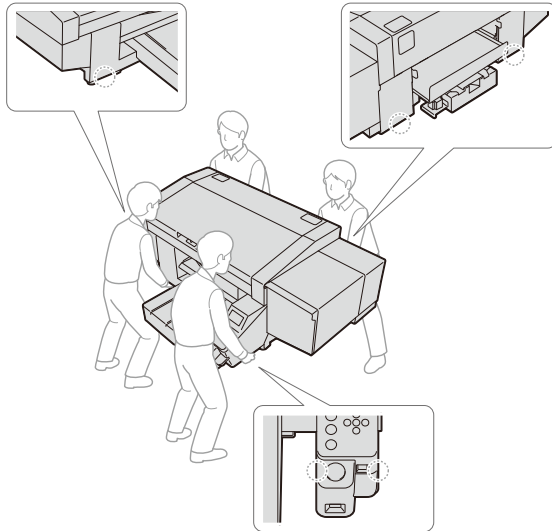

X0353

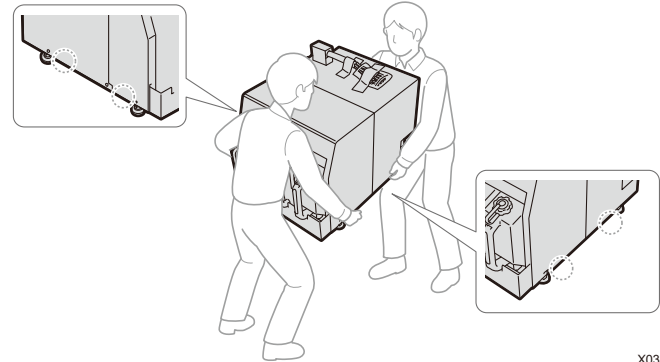

X0357

CAUTION

The printer machine weighs 171 kg (main body 128 kg + tank unit 43 kg). Transporting and installing the printer requires four or more people to hold it at the ▼-marked positions (which are located where the printer can be held). Otherwise the machine may fall down, causing injury or resulting in failure of the printer.

Setup of the printer

1 Removing the protection materials

Remove all the tapes, strings and sheets shown in the below illustration.

Main body

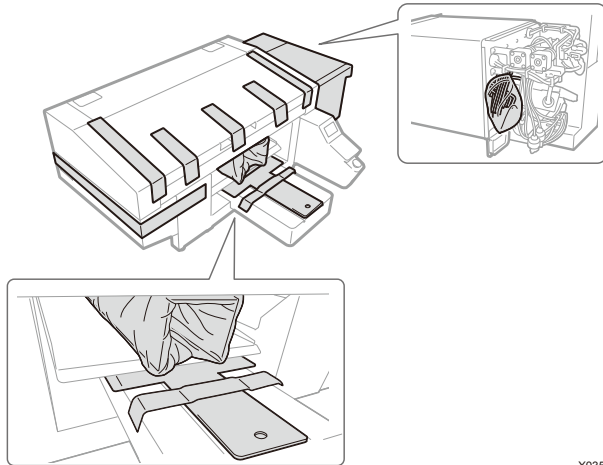

X0358

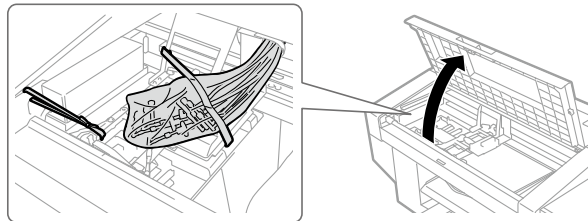

X0005

Tank unit

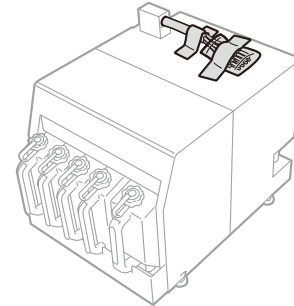

X0382

2 Main body and tank unit connection

Tube connection

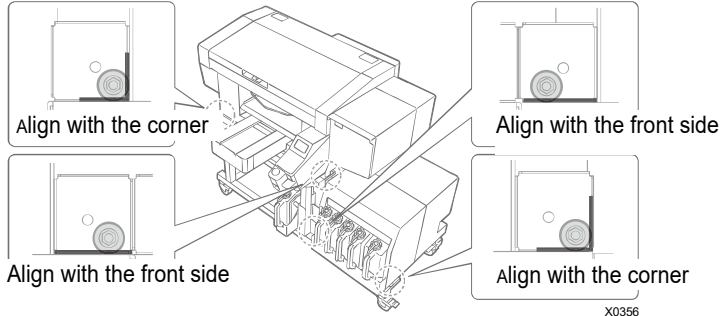

IMPORTANT

Make sure the main body and tank unit are in place before connecting the tubes.

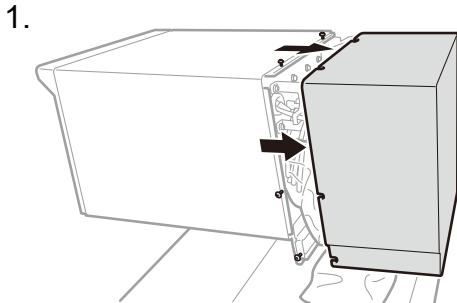

Loosen the screws of the right cover of the main body unit and remove the cover.

2.

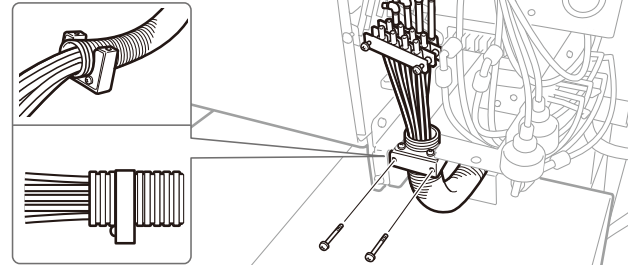

Mount the bracket with screws.



TIPS

If the bracket comes off, insert it into the third groove from the tube end.

3.

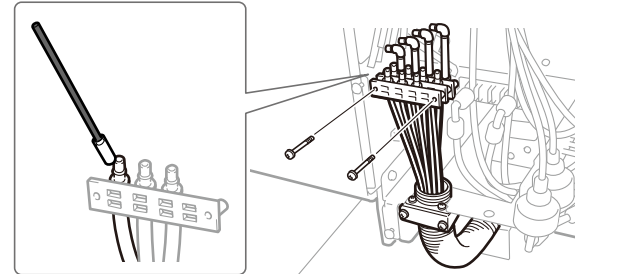

Remove the screw binding the tube and apply maintenance solution to the tip of the tube.



TIPS

Perform steps 3 and 4 for each tube.

Setup of the printer

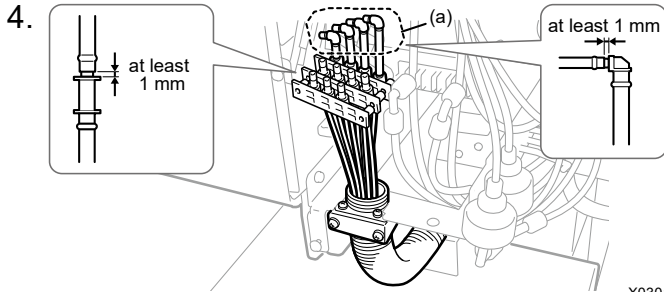

Check that the lower tube marker and the main body tube checker are matched and connect the tubes one by one from the main body side tube (a).

IMPORTANT

Avoid intersecting the tubes when connecting them.

Secure a clearance of at least 1 mm when connecting the tubes.

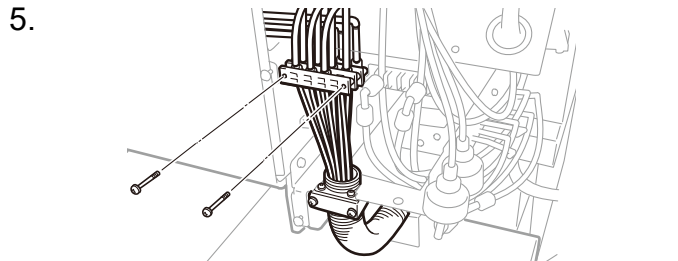

Mount the fastening holder with screws.
Install the removed right cover and tighten the screws.

Electric wiring connection

1.

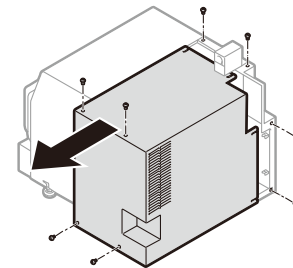

Remove the tank unit screws, and remove the cover by lifting it up a little and drawing it out in the arrow-pointed direction.

2.

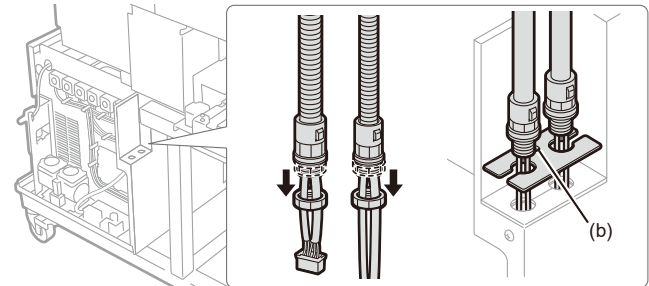

Loosen the nut and fit the connector cover with the harness.



TIPS

The connector cover hole (b) may be oriented to either side.

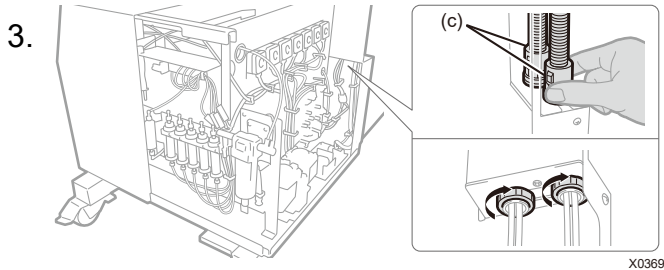

X0369

3. Insert the harness into the insertion slot and tighten the nut from below.



Press down the connector (c) while tightening the nut.

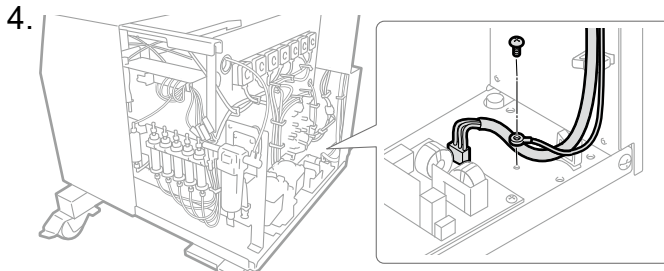

X0473

4. Fasten the earth wire with the screw and connect the connector to the board.

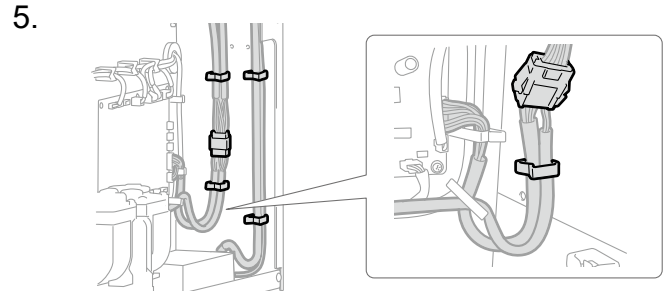

X0451

5. Connect the relay connector and fasten the harness with four clamps.

IMPORTANT

Slacken the harness in a U shape to make ease of draining when connecting the relay connector.



TIPS

Fasten the relay connector between clamps.

6.

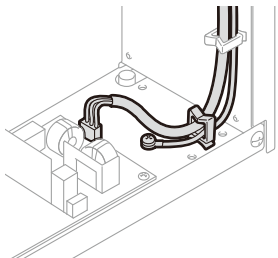

Fasten the earth wire and harness with clamps.

X0372

IMPORTANT

Be sure to fasten the harness with clamps.

7.

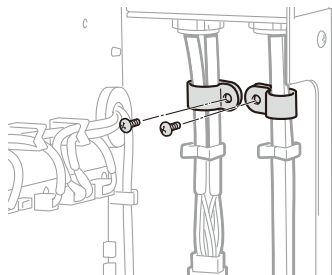

X0373

Fasten the harness with two cord holders.
Install the removed cover and tighten the screws.

3 Mounting the supplied accessories

Mount the supplied accessories according to the following procedures.

Please note that the platen should be mounted after turning on the power.

Rear cover

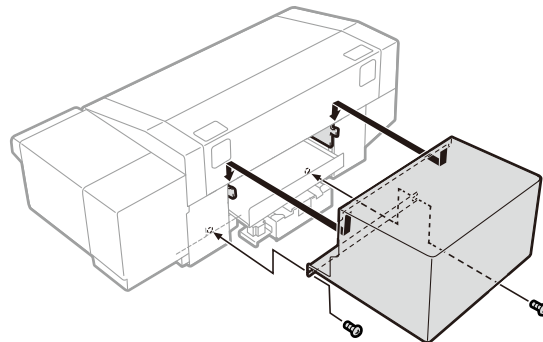

X0359

CAUTION

Be careful not to touch the claws of mounting portion on the upper side of the rear cover. Otherwise you may be injured.

Cable clamp

This is used to put the cables together.

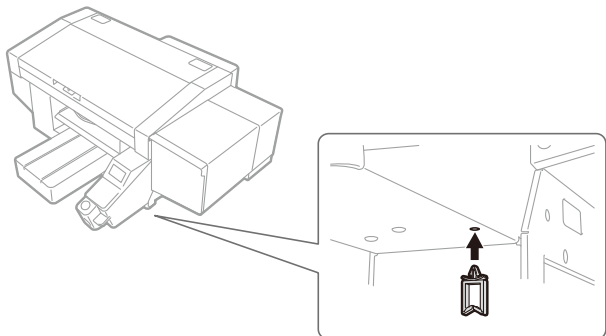

X0360

Filter cover and Fan filter

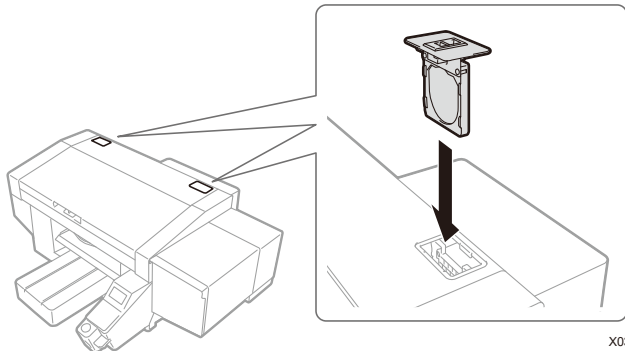

X0361

Waste ink tank

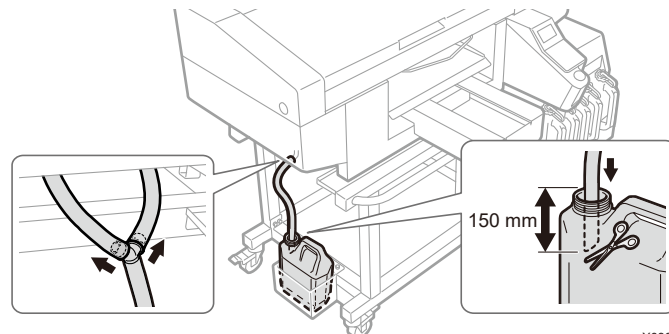

X0362

Insert the waste ink tube into the main body. Fasten the waste ink tank to the table leg or the like by using two pieces of string, etc. Insert the waste ink tube into the waste ink tank.

IMPORTANT

If the tip of the waste ink tube is immersed in the liquid, it will prevent the smooth flow of the waste ink, to disable the ink suction operation of the head cleaning function. After the waste ink tank is fastened, the waste ink tube should be cut so that the length from the tube connection is 150 mm. The waste ink tube should be cut diagonally.

Avoid placing the waste ink tube horizontally as much as possible, and be sure not to let it bend. Otherwise the waste ink may have difficulty flowing through the tube.



The table provides a place where to install the waste ink tank. Install the waste ink tank there.

Mount the following supplied accessories inside the printer.

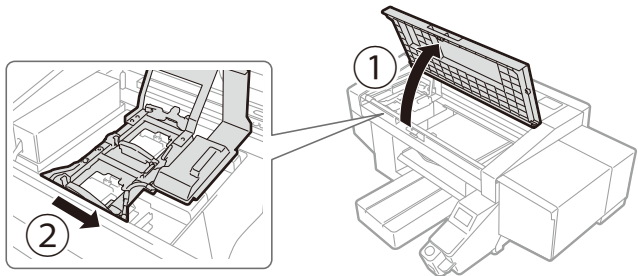

X0363

Open the cover to the direction ① and shift the carriage to direction ②. Put on the gloves that came with the printer and perform the following work.

Flushing receiver

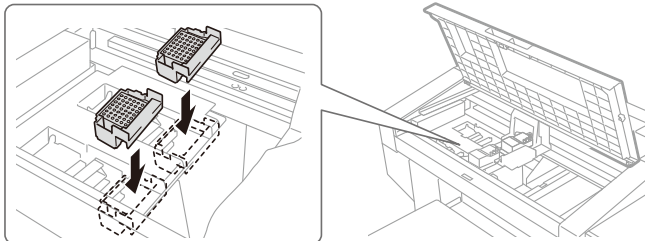

X0348

Install the printer with the hole on the bottom oriented to the front (there is no difference in white and color sides; they can be mounted on either side).

IMPORTANT

Make sure that no flushing foam extends off the outboard end portions of the flushing receiver. If it does, it may interfere with the nozzle surface of the head and may result in a problem concerning firing of the print heads.

Carriage fixing pin

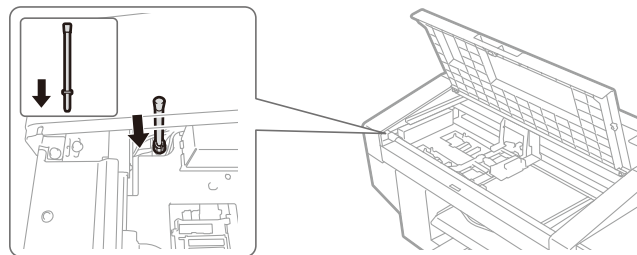

X0187



TIPS

The carriage fixing pin will be needed when the power is turned OFF due to power outage while the printer is running and the recovery is not expected for a while. Secure the pin in the place illustrated above so as not to lose it.

The front cover will not close completely if the carriage is fixed with the carriage fixing pin.

Wiper cleaner

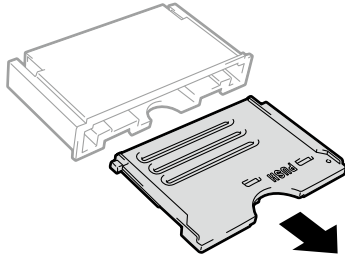

X0120



Waste should be disposed of in accordance with regulations and laws.

Use the cleaner by expiration date written on the label. Mount it on the machine immediately after it is unpacked.

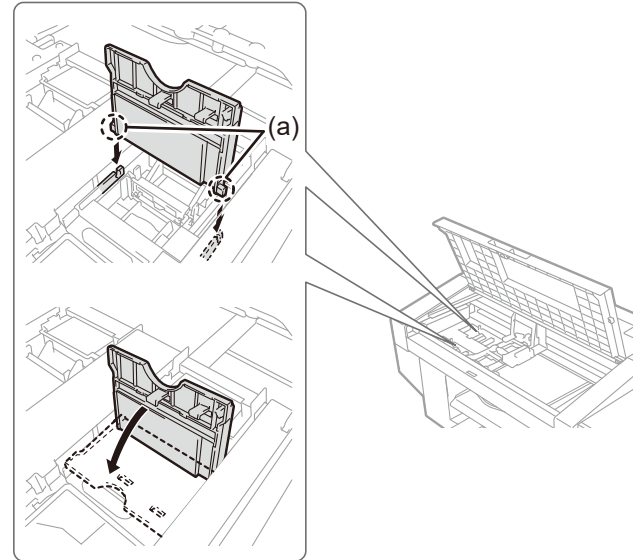

X0349

Insert the shaft (a), and push the area with the "PUSH" indication until it clicks (there is no difference in white and color sides; they can be mounted on either side).

Print head

1.

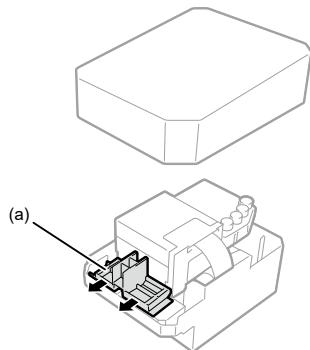

X0009

IMPORTANT

When you unpack the head, be careful not to touch the bottom of the head. Otherwise it may cause poor printing.

When you mount the head, shift the carriage toward the center of the printer; to the position above the platen. If you perform the mounting of the head when the carriage is directly above the maintenance unit, it may damage the maintenance unit or the heads.



TIPS

Do not confuse the color side print head with the white side print head. The color side (red) print head is located in front and the white side (white color) print head on the back.

The gray area (a) illustrated above may be hard and difficult to remove. If it is, use both hands to remove it.

2.

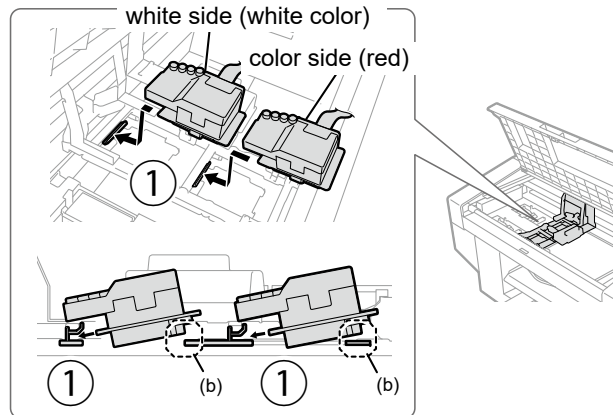

X0375

Insert the head firmly to direction ①.

IMPORTANT

If the print head is not inserted sufficiently, the part as illustrated in (b) could come into contact with its bottom surface, which in turn may result in poor printing. Make sure to insert it to the end.



CAUTION

When mounting the head, be careful not to move the carriage as much as can be avoided. Your hand may be caught in the carriage and injured. In addition, the tubes may be rolled together possibly damaging them.

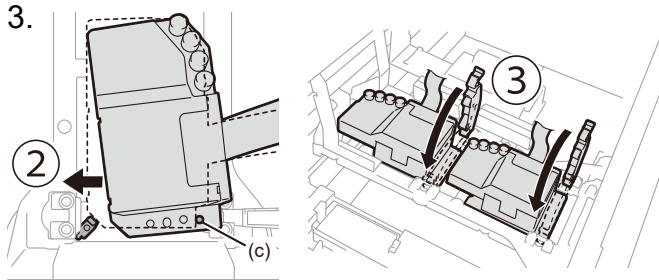

X0376

Push with force in the direction as indicated in ② so that the (c) area makes contact with the side of the metal plate of the head.



CAUTION

When you mount ③, hold it down from the top. Otherwise your finger may be pinched and injured.

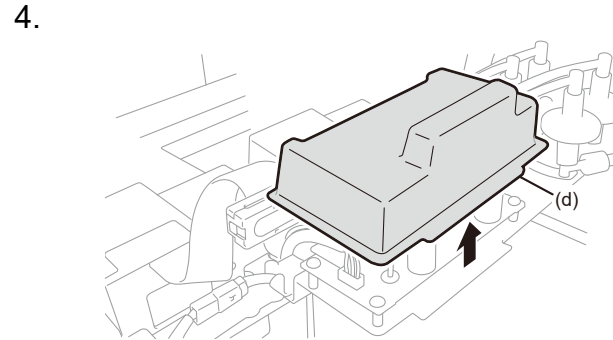

X0427

Unhook the two claws of the resin cover (d) to remove the resin cover.

5.

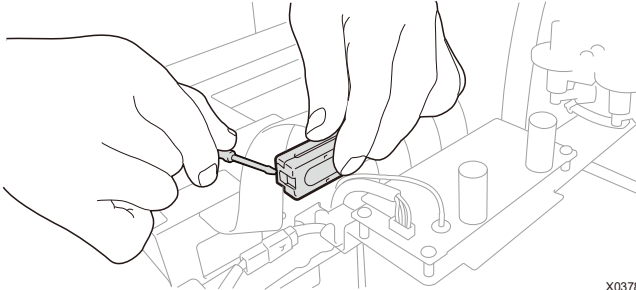

X0378

Remove the core claw using the supplied screwdriver.



TIPS

Hold the core center by hand to make it easy to insert the screwdriver into the claw.

6.

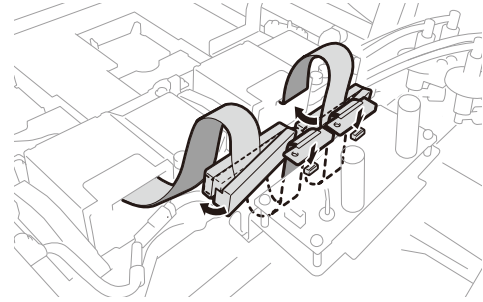

X0379

Connect the flat cable by fitting it with the core. Fit the claw by pushing the core until it clicks into place. Leave a slack to avoid interference with the resin cover.

7.

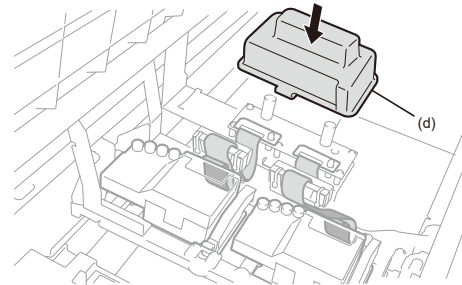

X0377

Hook the two claws of the resin cover to mount the cover (d). Tuck the extra flat cable as shown in the illustration.

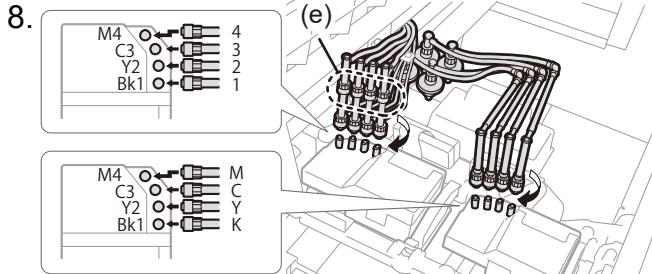

X0380

Remove four caps of the head.

Check that the head and the marker of each tube are matched and connect the tubes one by one from back to front of the machine by rotating the nut until it stops.

IMPORTANT

Do not rotate the nut as illustrated in (e). It could disconnect the tube and leak the contained ink.

Be sure to remove the caps attached to the head before connecting.

4 Cleaning liquid tank

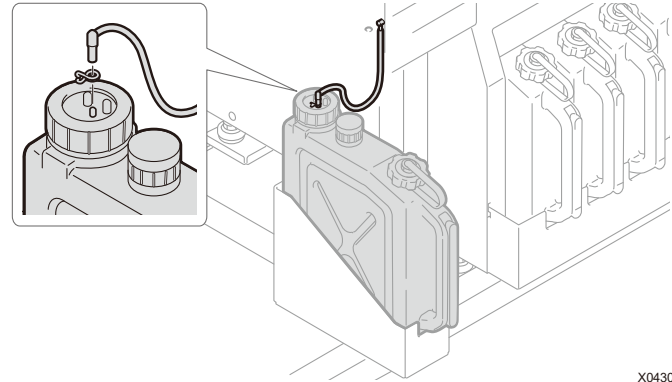

X0430

Attach the clip to the tip of the tube on the tank unit side and insert it into the cleaning liquid tank.

Pinch the tube with a clip to prevent it from coming off.

IMPORTANT

Completely connect the tube to prevent it from coming off.

5 Turning on the power

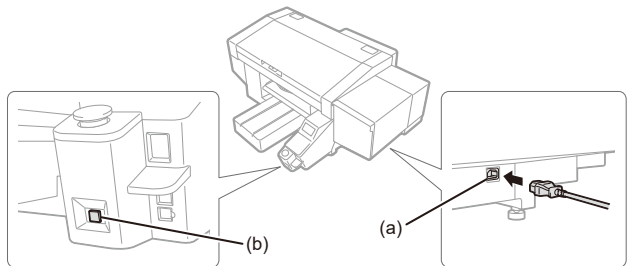

X0364

Close the cover of the machine and insert the AC power cord into (a) and the outlet.

Press the power button (b) to turn the printer power ON.



Error messages "Perform Initial Ink Installation" and "Please Refill Ink" may be displayed on the screen of the printer but it will be no problem, so please continue to perform the ink installation according to the procedures described in this manual.

6 Filling the cleaning solution

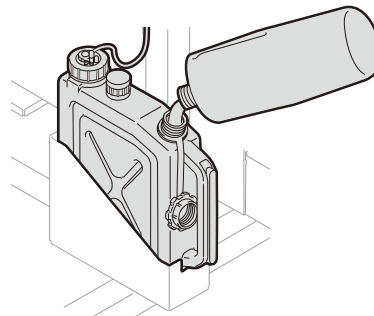

X0365

- 1) Open the cleaning liquid tank lid and fill the tank with the cleaning liquid.
- 2) Close the cleaning liquid tank lid.

IMPORTANT

Take care to prevent the cleaning liquid from leaking when filling it.



After filling the cleaning liquid, be sure to close the cleaning liquid tank lid.

7 Refilling the ink

Turn on the power of the printer and perform the operation while the printer is in Standby mode.

CAUTION

Be sure to wear a pair of plastic gloves and protective glasses while refilling the ink.

IMPORTANT

Agitate the white ink before refilling.
For details, refer to the Instruction Manual.

For information on using the 18 L refill ink tank to refill ink, refer to the Instruction Manual.



TIPS

When agitating the white ink, remove the IC stick to prevent it from falling off.

1)  →[Refill Ink]→Select the color you want to refill→



2) Insert the IC stick of the same color as the ink to refill→



TIPS

An error appears if you insert an IC stick of a different color.

3) Refilling the ink.

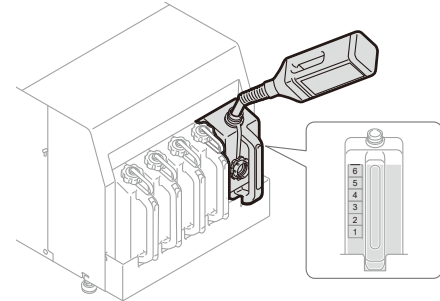

X0366

IMPORTANT

Be sure not to refill the ink above the upper graduation mark in 6.

4) Follow the instructions on the screen.

IMPORTANT

Be sure to close the ink tank lid once you have refilled the ink.

Discard the supplied filler nozzle once you have used it.
Do not use a non-standard funnel or other part because doing so may cause ink contamination or deterioration, possibly resulting in printer failure.



X0431

IMPORTANT

Take care not to lose the IC stick that comes standard with the refill ink bottle.



TIPS

Store the IC stick by attaching it to the handle of the refill ink bottle.

Waste should be disposed of in accordance with regulations and laws.

8 Mounting the platen

1.

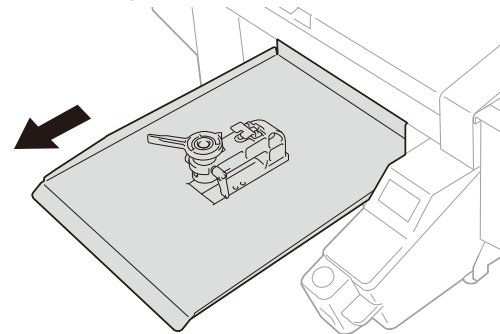

Press  on the operation panel to move the platen to the front.

X0374

2.

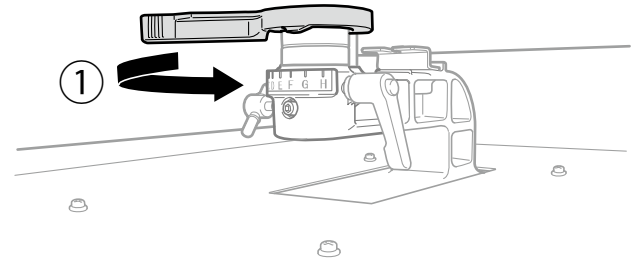

X0288

Rotate the platen height adjustment lever in direction ①, and align the scale to position "A".

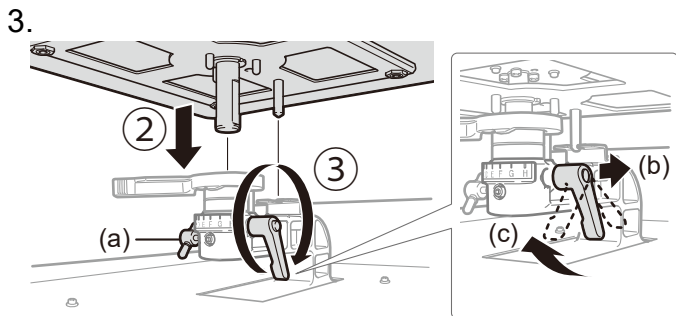

X0428

Insert the platen in direction ② and tighten the platen fixing lever in direction ③.



TIPS

Use with the knob (a) tightened when printing.

Depending on the height of the platen, the platen fixing lever may strike against the platen, and prevent rotation. In that case, move the platen fixing lever in the direction (b), draw the edge of the platen fixing lever forward as shown in (c), then loosen it again.

9 Configuring the language

Perform this operation while the printer is in Standby mode.

- 1) **MENU OK** -> [Language] -> Select your language -> **MENU OK**
- 2) Press the power button to turn off the power.

10 Installing the ink

Turn on the power of the printer and perform the operation while the printer is in Standby mode.

- 1) **MENU OK** -> [Maintenance] -> [Initial Ink Installation] -> [All Print Heads]
- 2) Follow the precautions on the screen and press **MENU OK** (it takes about 90 minutes and further takes about 30 minutes if below 18°C).
- 3) When the printer returns to Standby mode, the operation will be completed.

IMPORTANT

After completing the ink installation, check the following:

- Check that the tube is filled with ink and contains no air.
- Check that the ink has reached the print head.

If the above conditions are not met, proceed with the following steps:

- MENU OK** -> [Maintenance] -> [Install Ink after Replacing Head]

Connection to a PC



Although the description of this section is based on operation with Windows, you can also use Macintosh.
For details, refer to the Instruction Manual.

1 Installing the driver

- 1) Download the ZIP file from our website and unzip the file.
- 2) Double-click on "setup.exe" -> Activate the installer
- 3) Follow the instructions on the screen.
- 4) After the installation, restart the PC.

2-A When connecting via USB

- 1) Connect the printer and PC via a USB2.0 cable.



When putting the USB cable and LAN cable together, use "P.11 Cable clamp".

- 2) Follow the instructions on the screen.



This screen may prompt more than once.
And this also may require several minutes to complete.

We recommend you to set "Brother GTX pro" or "Brother GTX pro FileOutput" as the default printer for your convenience.

2-B When connecting via LAN

Assignment of printer static IP address



The printer may not be recognized depending on your security environment. Consult the system administrator of the setting site.

The static IP address can also be set on the printer. For details, refer to the Instruction Manual.

- 1) Perform the procedures of "P.22 When connecting via USB".
- 2) Start menu -> "Brother GTX pro Tools " -> Activate " GTX pro Maintenance "
- 3) Select [Set an IP Address] -> [Next]

- 4) Select the setting method -> [Next]

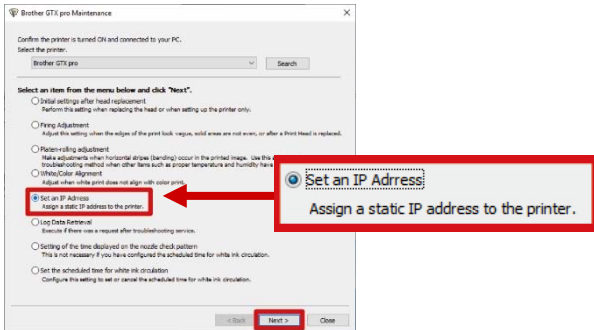
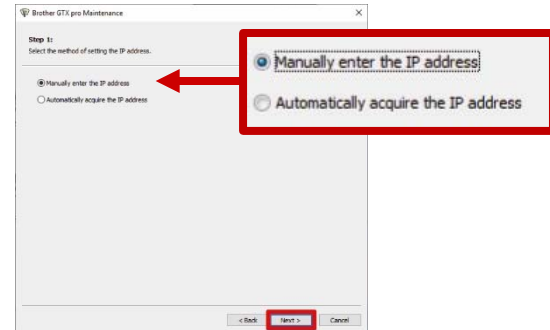

If you selected "Manually enter the IP address"

- 5) Enter the values of [IP Address][Subnet Mask][Default Gateway] -> [Next]. The steps are completed when the message [IP address was successfully assigned to the Printer.] is displayed.

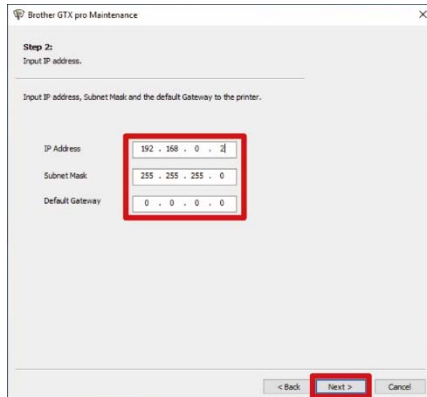

Brother GTX pro Maintenance

Step 2:
Input IP address.

Input IP address, Subnet Mask and the default Gateway to the printer.

IP Address	192 . 168 . 0 . 2
Subnet Mask	255 . 255 . 255 . 0
Default Gateway	0 . 0 . 0 . 0

< Back **Next >** Cancel

If you selected "Automatically acquire the IP address"

- 5) Enter the hostname -> [Next]. The steps are completed when the message [IP address was successfully assigned to the Printer.] is displayed.

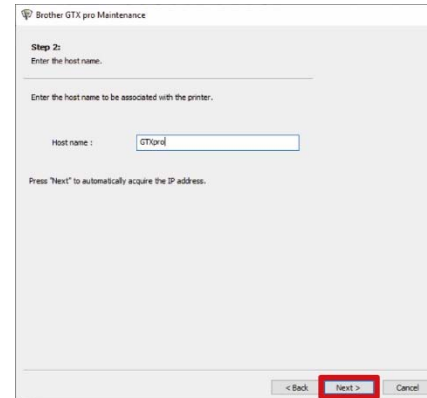

Brother GTX pro Maintenance

Step 2:
Enter the host name.

Enter the host name to be associated with the printer.

Host name : GTXpro

Press "Next" to automatically acquire the IP address.

< Back **Next >** Cancel

Installing the network print driver

- 1) Connect the printer and PC to a network using LAN cables and turn the printer power ON.
- 2) Windows 10: [Settings] -> [Devices] -> [Printers & scanners] -> click [+]
Windows 11: [Settings] -> [Bluetooth & devices] -> [Printers & scanners] -> click [Add device]



- 3) Windows 10: [The printer that I want isn't listed] -> select [Add a local printer or network printer with manual settings] -> click [Next]
Windows 11: Select [Add manually] -> click [Next]

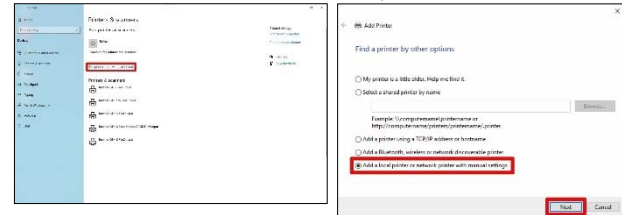

- 4) Select [Create a new port] -> From [Type of port], select [Standard TCP/IP Port] -> [Next]

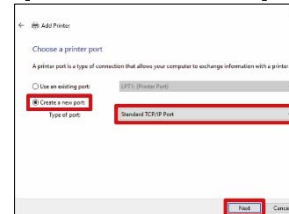

Connection to a PC

- 5) Enter the static IP address of the printer into [Hostname or IP address] -> Uncheck the check box of [Query the printer and automatically select the driver to use] -> [Next]



You can omit steps 6) through 8) if the printer driver to use is automatically selected. Follow the steps if it cannot be selected automatically.

If you set the printer's IP address by automatic acquisition, you must check the IP address of the printer in advance. You can confirm the IP address by selecting [Confirm network setting] -> [IP Address] from the menu. For details, refer to "8-23. Confirm network setting" in the Instruction Manual.

If you are using a DNS server, you can use a host name and domain name instead of the IP address. In that case, enter the host name that has been acquired automatically and set for the printer IP address (see P.24). As for the domain name, check with your network administrator.



TIPS

When the printer screen displays "00X", enter "X" in the IP address field.

- 6) From [Device Type], select [Custom] -> [Settings]

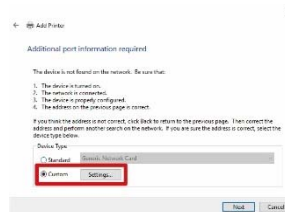

- 7) From [Protocol], select [LPR] -> Enter "BINARY_P1" in the [Queue Name] of [LPR Settings] -> [OK] -> [Next]

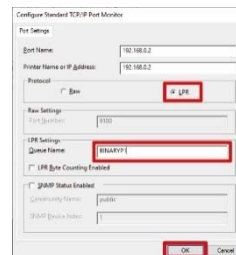

TIPS

8) From [Manufacturer], select [Brother] -> From [Printer], select [Brother GTXpro] -> [Next].

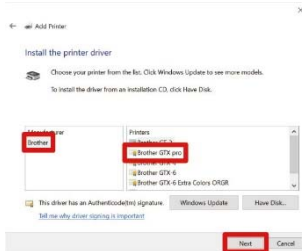

9) Select [Replace the current driver] -> [Next]

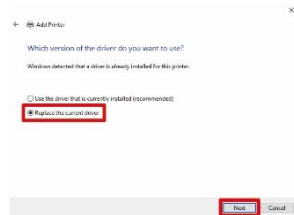

10) Enter the [Printer name] -> [Next]

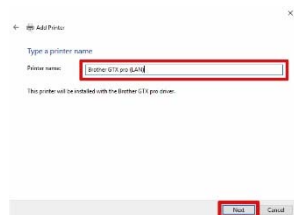

11) Select [Do not share this printer] -> [Next] -> [Finish]

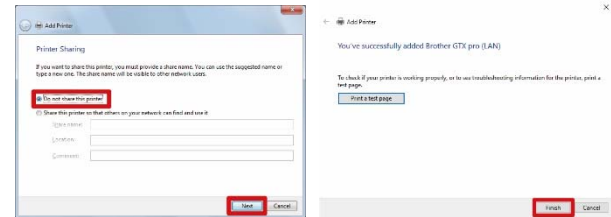

Adjustment

1 Adjusting the carriage speed

Perform the operation while the printer is in Standby mode.

1)  -> [Printer Setting] -> [CR Speed Adjustment] ->

[Start (after cleaning/setup)] ->  (It takes about 3 minutes.)

2) When the printer stops with a sound and the printer returns to Standby mode, the operation is completed.

2 Checking the nozzle check pattern

1) Make sure that the platen height adjustment lever (a) is set at the "A" position.

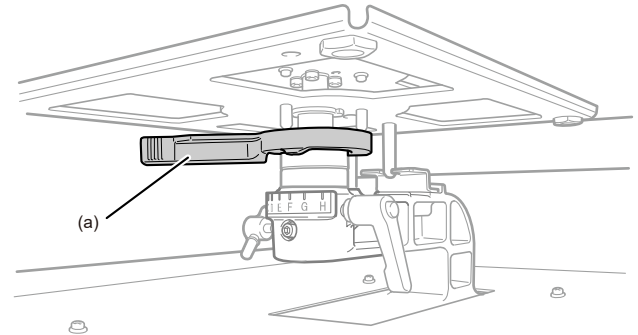

X0290



Use a platen sized 14 in. x 16 in. (356 mm x 406 mm), which is included at the time of your purchase.

- 2) Place a sheet of A4 or letter-size white paper as illustrated below (Pretreated T-shirt is also acceptable).
If the paper tends to be floated, tape the corners.

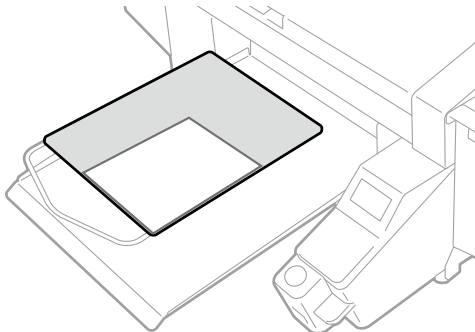

X0452

- 3) Perform the following operation on the screen of the printer:

MENU OK -> [Test Print] -> [Nozzle Check CMYK] -> **MENU OK**

- 4) When printing is finished and the printer returns to Standby mode, set a piece of black paper or transparent sheet (such as OHP sheet) of A4 or letter size in the same manner as step 2 (A pretreated black or dark color T-shirt is also acceptable).

5) **MENU OK** -> [Test Print] -> [Nozzle Check White] -> **MENU OK**

- 6) Check the printed results for both nozzle check prints and determine if there is a problem.
If missing nozzles are found as indicated by the arrows below, there is a problem concerning the firing of the print heads.

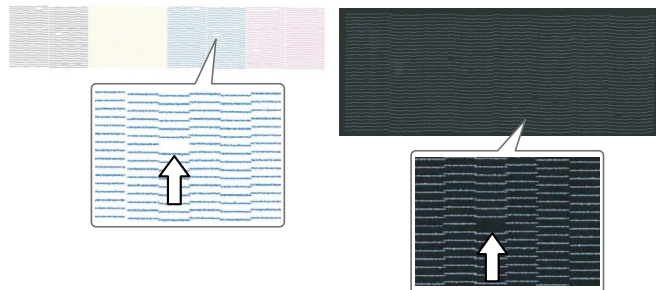

X0291



TIPS

Even if the lines of the white-side printed result are light, since white ink is fired from more than one nozzle on the same place, the quality is not affected.

- 7) If any problem is found, perform a normal cleaning.
While the printer is in Standby mode, press , select the head with the problem, and press **MENU OK**.
- 8) Check the nozzle check pattern again.
If the problem still persists, please contact your dealer.

3 Making adjustments after the print head is mounted

- 1) Connect the printer and PC via a USB 2.0 cable or LAN cable. On the PC side, "Brother GTX pro Tools" → Activate "GTX pro Maintenance".
- 2) Prepare a few sheets of A4 or letter-size paper (black paper or transparent sheet such as OHP sheet and white paper), tape for fixing the paper, and a pretreated black or dark color T-shirt.



For details for pretreatment, refer to the Instruction Manual.

- 3) Following the instructions on the "GTX pro Maintenance" screen, run the following menu options.

	Menu name	Things to prepare
1	[Initial settings after head replacement] *1	—
2	[Firing Adjustment]	Black paper or transparent sheet (such as OHP sheet) White paper
3	[Platen-Rolling Adjustment]	White paper
4	[White/Color Alignment]	Black paper or pretreated black or dark color T-shirt
5	[Setting of the time displayed on the nozzle check pattern]	—

*1: In [Initial settings after head replacement], set the values written on the print head or the container.



Maintenance list

To maintain the printing quality and use the printer for a longer time, the following maintenance is needed.
For details, refer to the Instruction Manual.

Maintenance timing	Description	Error / Warning display
Before printing	Confirmation and disposal of waste ink	—
	Confirmation and refilling of cleaning solution	○
	Print out of the nozzle check pattern (checking on the print heads)	—
When an error / warning is displayed	Refilling ink	○
	Cleaning of the nozzle guard, wiper, exhaust cap and suction cap	○
	Replacing the wiper cleaner	○
	Replacing the flushing foam	○
	Replacing the fan filter	○
When the printer becomes dirty	Head cleaning	—
	White ink circulation	—
	Cleaning the CR (carriage) plate	—
	Cleaning the internal area of printer	—
	Replacing the platen sheet	—



*Please note that the contents of this manual may differ slightly from the actual product purchased as a result of product improvements.

BROTHER INDUSTRIES, LTD. <https://www.brother.com/>

1-5, Kitajizoyama, Noda-cho, Kariya 448-0803, Japan.

© 2020-2024 Brother Industries, Ltd. All Rights Reserved.

This is the original instructions.

GTX-424
SC4925-101 EN
2024.07.F(1)