

DTRX001

Professional Use

Powder Shaker

Instruction Manual



Please be sure to read this manual before using this product.

Keep this manual in a safe place for future use.

This machine should only be used by operators who are appropriately trained in its safe operation.

Contents

Chapter 1 SAFETY INSTRUCTIONS.....	4
1.1 Safety Indications and Their Meanings.....	4
1.2 Notes on Safety.....	5
1.3 Warning Labels.....	12
Chapter 2 Before Using Your Machine for the First Time.....	14
2.1 Checking the installation environment.....	14
2.2 Connecting to the printer.....	16
2.3 Installation of supplied accessories.....	16
2.3.1 Check the components included with the machine.....	16
2.3.2 Mounting the supplied accessories.....	17
2.4 Other items required.....	19
2.5 Power connection.....	20
2.6 Power operations.....	21
Chapter 3 Basic Information.....	22
3.1 Specifications.....	22
3.2 Names of each component.....	23
3.3 Description of sensors.....	28
3.3.1 Safety-related sensors.....	28
3.3.2 Operation-related sensors.....	29
3.4 Panel menu list.....	30
Chapter 4 Basic Operations.....	33
4.1 Loading the media.....	33
4.2 Loading the powder.....	36
4.3 Storage of media and powder.....	38
4.4 Automatic operation procedure.....	39
4.4.1 Operating principle.....	39
4.4.2 Operating procedure.....	40
4.5 Setting values for printer-linked operation.....	42
Chapter 5 Maintenance.....	44
5.1 Confirmation before starting the operation.....	44
5.2 Daily maintenance.....	44
5.2.1 Reusing the powder.....	44
5.2.2 Cleaning scattered powder and oil.....	45
5.3 Weekly maintenance.....	46

5.3.1	Checking and disposing of waste oil.....	46
5.3.2	Checking the oil contamination of the filter section.....	47
5.3.3	Cleaning oil inside the heater oven cover.....	48
5.3.4	Cleaning the heater tubes and stainless-steel parts.....	49
5.4	Monthly maintenance.....	50
5.5	Regular filter replacement.....	51
5.6	Waste oil handling procedure.....	54
5.7	When not used for a long period of time.....	54
Chapter 6	Troubleshooting.....	55
6.1	In case of the following problems.....	55

Chapter 1

SAFETY INSTRUCTIONS

Thank you very much for purchasing this product.

Before using the product, read the “SAFETY INSTRUCTIONS” and handling instructions carefully.

Please keep this manual within easy reach for quick reference.

For details of the setup manual, please refer to the mobile application at the QR code link below.

- The Brother GT/ISM Support App is a mobile app that provides up-to-date support information on garment printers, industrial sewing machines, and industrial printers. When selecting the product, choose it from [Industrial Printer] > [Wide Format].
 - With this application, you can download and view the Setup Guide, the Instruction Manual, other manuals, a list of parts (the Parts Book) required for regular care and repairs, and a video on maintaining your equipment.
 - Search by Error code.
 - Downloaded contents can be seen offline.



1.1 Safety Indications and Their Meanings

This instruction manual and the indications and symbols that are used on the machine itself are provided in order to ensure safe operation of this machine and to prevent accidents and injury to yourself or other people.







The meanings of these indications and symbols are given below.

Indications

▲ DANGER	The instructions which follow this term indicate situations where failure to follow the instructions will result in death or serious injury.
▲ WARNING	The instructions which follow this term indicate situations where failure to follow the instructions could result in death or serious injury.
▲ CAUTION	The instructions which follow this term indicate situations where failure to follow the instructions may result in minor or moderate injury.
ⓘ IMPORTANT	The instructions which follow this term indicate situations where failure to follow the instructions may result in damage to property.
ⓘ NOTE	The instructions which follow this term indicate precautions and restrictions for use.

Symbols

	This symbol indicates something that you must not do.
---	---

	This symbol indicates that getting wet is prohibited.
	This symbol indicates that disassembly is prohibited.
	This symbol indicates parts or components that must not be touched.
	This symbol indicates something that you must do.
	This symbol indicates that the grounding wire must be connected.
	This symbol indicates that the power plug must be unplugged immediately.

1.2 Notes on Safety

Basic information

DANGER



Contact with high-voltage parts may lead to serious injury. Turn off the power, disconnect the power cord, and remove power unit protection cover after waiting 5 minutes.

 **WARNING**



The machine should only be used by operators who are appropriately trained in its safe operation.



The machine is not suitable for use in places where children are present.



To prevent accidents and malfunctions, do not modify the machine yourself. Brother will not be held responsible for any accidents or problems resulting from modifications made to the machine.



Do not handle the power plug with wet hands. Otherwise, it may cause electric shock.



Do not allow the machine to come into contact with liquids. Otherwise, it may cause fire or electric shocks or malfunction.



Do not place containers containing liquids on top of this machine.



In the following circumstances, immediately turn off the power, disconnect the power cord, and contact the place of purchase or a qualified technician:

- If foreign matter or liquid has entered the interior of the machine
- If the machine has been dropped
- If smoke is coming from the machine or an unusual odor is detected

If you continue to use the machine in the above circumstances, it may result in fire or electric shocks or malfunction.

 **CAUTION**



When malfunction occurs with the operation of the machine, contact your dealer or a qualified technician.



Use the machine in a place which is adequately ventilated. A slight odor is generated when the media and powder are being fixed by heat.

Unpacking, transport, and installation

WARNING



Unpacking, transporting, and installing this machine must be performed only by a qualified technician.



Do not set up the machine in a dusty environment. If dust collects inside the machine, it may cause fire, electric shocks, or problems with correct operation.



When lifting this machine with a forklift or similar equipment, lift it horizontally so that it does not tilt. Failure to do so may result in injury due to the machine falling or product malfunction.



When lifting the machine from packaging materials such as its pallet or when moving it, clear the area around your feet and ensure safety before starting work. Failure to do so may result in injury due to tipping or dropping of the machine, or product malfunction.



Be sure to connect the ground. Failure to do so may cause electric shock or malfunction.



Do not forcibly bend or crush the cord. Doing so may cause fire or electric shock.

 **CAUTION**



The machine weighs 400 kg (882 lb). When transporting or installing the machine, follow the correct holding method for the machine. Failure to do so may result in injury due to the machine falling or product malfunction.



Do not place the machine on a shaky table or high shelf or other unstable location. Doing so may result in injury due to tipping or dropping of the machine, or product malfunction.



Do not set up the machine in a place where it will be affected by vibration. Doing so may cause deterioration in print quality, injury due to machine movement, or product malfunction.



Do not connect the power cord until installation is complete. The machine may operate if the power is turned on by mistake, which could result in injury.



Do not climb onto the machine or place heavy objects on top of it. Doing so may cause injury due to tipping or falling.

 **IMPORTANT**



The lower part of the machine is equipped with four casters with stoppers. During installation, secure the machine using the stoppers.

Operation

WARNING



Do not bring fingers or body parts close to rotating fans or rollers. Doing so may result in entanglement and injury.



When opening the upper heater oven cover for media installation or replacement, ensure that the heater and the media do not come into contact. Heat from the heater may deform or melt the media, causing fire or malfunction.



The inside of the oven reaches temperatures exceeding 100°C (212°F) during operation. When opening the heater oven cover for media replacement, turn off the power and confirm that the temperature has decreased before opening. Failure to do so may result in burns.

CAUTION



Do not touch the media during operation. Doing so may result in injury, such as fingers being caught.



Do not put your hands inside the covers while the machine's power is turned on. Otherwise, your hands may touch against moving parts, and this may result in injury.



Powder will scatter during powder loading. Wear vinyl gloves, a mask, and protective goggles, and ensure sufficient ventilation during work.



When opening the heater oven cover for media installation or replacement, do not touch the heater. Heat from the heater may cause burns.



When installing or replacing media, be careful not to bump, rub, or pinch your hands or fingers. Failure to do so may cause injury.

Maintenance

WARNING



When opening the machine's heater oven cover, turn off the power and confirm that the temperature has decreased before opening. Failure to do so may result in burns.



When replacing heater tubes, turn off the power and confirm that the temperature has decreased before replacement. Failure to do so may result in burns or malfunction.

CAUTION



When closing the machine's covers, be careful not to pinch your fingers. Failure to do so may cause injury.



Do not ingest liquids or grease accumulated in the waste oil tray or filters. They may cause diarrhea or vomiting. Keep out of reach of children.



Liquids accumulated in the waste oil tray or filters, ink printed on media, powder, and grease may cause irritation if they come into contact with eyes or skin. In case of contact with eyes, do not rub but immediately rinse the eyes with water.



Follow the corresponding instructions in the manual when you put your hands inside the cover during regular maintenance while the power is turned on.



When replacing parts and installing optional accessories, be sure to use only genuine Brother parts. Brother will not be held responsible for any accidents or problems resulting from the use of non-genuine parts.



When replacing or cleaning parts or installing optional accessories, be sure to follow the procedures described in the Instruction Manual. Incorrect procedures could cause injuries or problems.

Others

Note



Use the machine in an area that is free from sources of strong electrical noise, such as electrical line noise or static electric noise. Sources of strong electrical noise may cause problems with correct operation.



Any fluctuations in the power supply voltage should be within $\pm 10\%$ of the rated voltage for the machine. Voltage fluctuations that are greater than this may cause problems with correct operation.



The power supply capacity should be greater than the requirements for the machine's power consumption. Insufficient power supply capacity may cause problems with correct operation.



In the event of an electrical storm, turn off the power and disconnect the power cord from the wall outlet. Lightning may cause problems with correct operation.

About trademarks

In this manual, the © marks or TM marks are not used.

Brother logo is registered trademark of Brother Industries, Ltd.

Other product and company names mentioned herein may be the trademarks or registered trademarks of their respective owners.

Information in this document and the specifications of this product are subject to change without notice.

About the CE declarations

Downloadable from: <https://www.brother.com>

1.3 Warning Labels



The following warning labels are attached to the machine.

Follow the precautions given on each warning label for your work.

If the label is peeled off or illegible, contact your dealer.

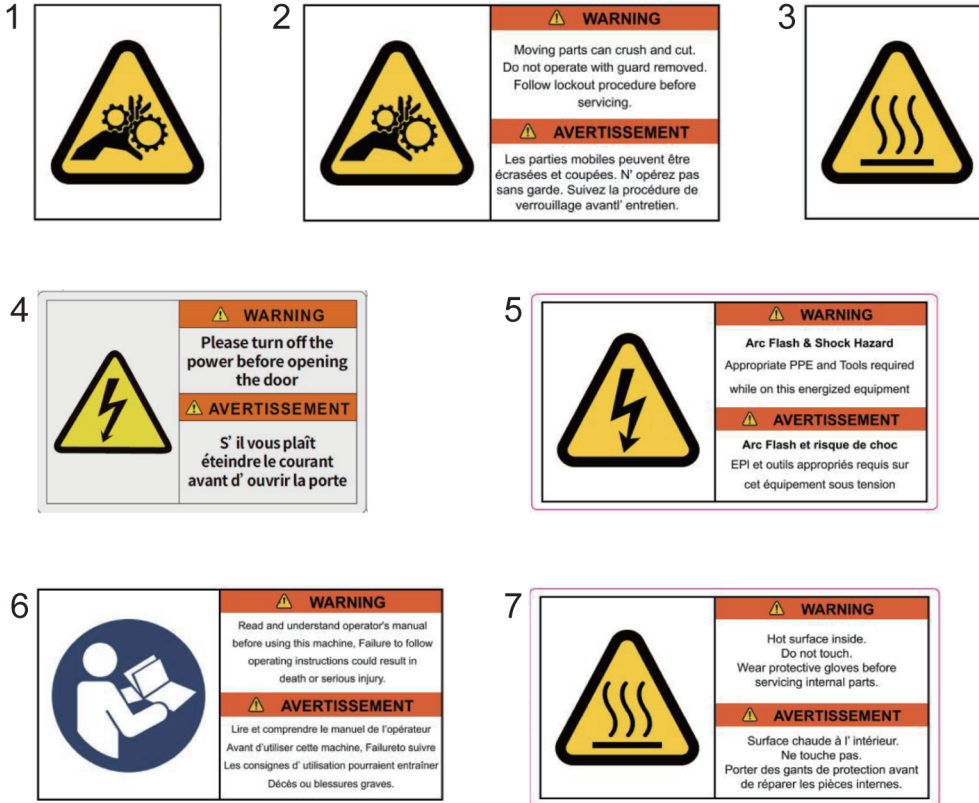

Chapter 2

Before Using Your Machine for the First Time

2.1 Checking the installation environment

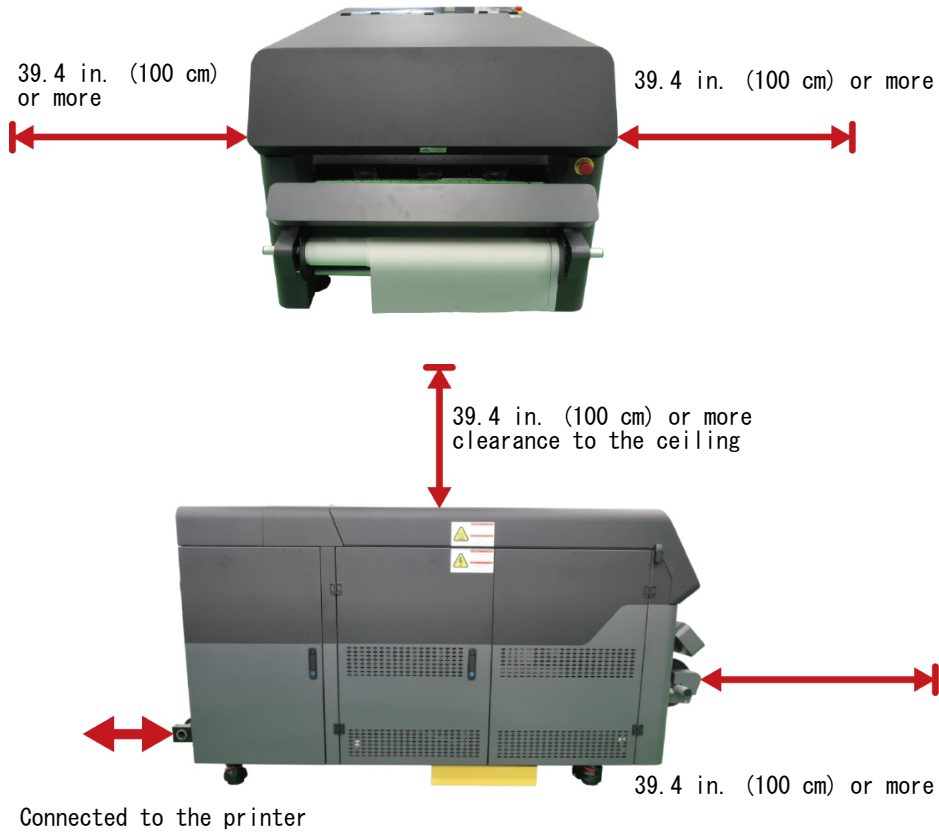

Chapter 2

Before Using Your Machine for the First Time

- Use the machine under the following environmental conditions.

Environment	Temperature	Humidity
Storage	0°C to 40°C (32°F to 104°F)	20 % to 85 % (no condensation)
Working Environment* ¹	18°C to 30°C (64.4°F to 86°F)	
Recommended Print Environment* ²	20°C to 28°C (68°F to 82°F)	35 % to 65 % (no condensation)

Electrical requirements	Power	Power consumptions
—	Single-phase 200 - 240 V, 16 A 50 / 60 Hz	4000 W

*¹: Environmental range where the printer can be operated

*²: Environmental range where sufficient printing quality can be secured

- Avoid any place that receives direct sunlight or has a large amount of dust.
- The main unit dimensions are 44.1 in. (width) × 76.8 in. (length) × 41.7 in. (height) (1120 mm (width) × 1950 mm (length) × 1060 mm (height)). The machine weighs 400 kg (882 lb).
- Do not use an extension cable.
- Leave at least 39.4 in. (100 cm) of working space on the left side, right side, rear, and above the machine. If this space is not secured, you will need to move surrounding equipment or the machine itself when replacing roll media, performing maintenance, or carrying out repairs.
- Install the machine on a floor that is as flat and level as possible to prevent wobbling.
- In preparation for major earthquakes or other disasters, lock the casters to prevent the machine from tipping over or moving significantly.
- When connecting the power cord to the machine, do not use a daisy chain.

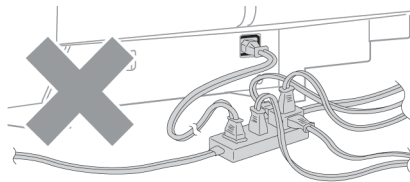

- Do not install the machine in the following locations.
 - Places where there is open flame
 - Places subject to vibration or shaking
 - Places with significant temperature or humidity fluctuations
 - Places where the machine may get wet
 - Places where corrosive gases such as ammonia or chlorine may be present
 - Places with insufficient ventilation

2.2 Connecting to the printer

When using a Brother DTRX100 printer, connect it to this machine.

For information on how to connect to a Brother DTRX100 printer, refer to the DTRX100 DTF Dedicated Printer Setup Manual, “Chapter 4 Connecting the powder shaker.”

The jig used to connect to and secure the printer are included with the printer.

2.3 Installation of supplied accessories

2.3.1 Check the components included with the machine

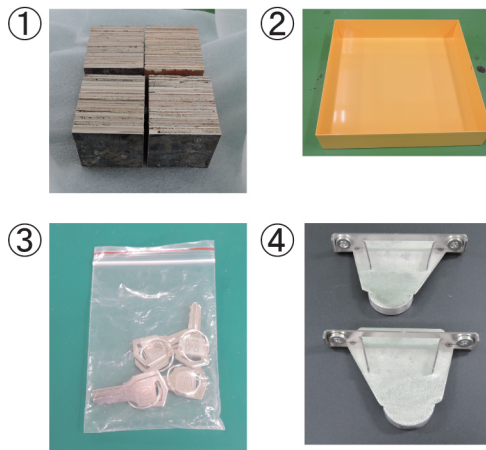

①	Wooden blocks ×4 (Do not discard them by mistake. They are used when lowering this machine from the pallet.)
②	Waste oil tray
③	Key (for opening and closing the cover on the side of this machine)
④	Guide fittings for both ends of the media ×2 (They are installed at locations in the media transport path where powder tends to accumulate on the media.)

2.3.2 Mounting the supplied accessories

Mount the supplied accessories according to the following procedures.

- 1 Open the side cover on the filter side and pass the waste oil drain tube (white) through the hole at the bottom so that it runs to the floor.

! IMPORTANT

- Be careful not to bend the waste oil drain tube. Otherwise, waste oil may not flow smoothly.

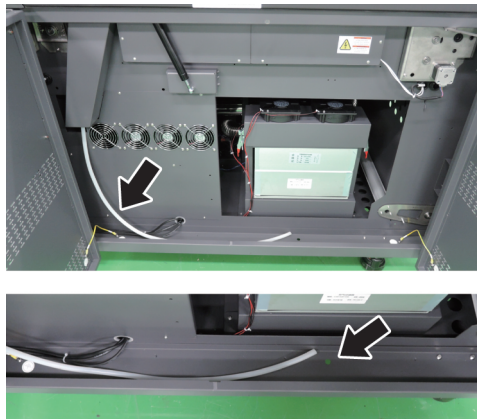

- 2 Place the waste oil tray on the floor beneath the drain tube outlet.

! IMPORTANT

- Position it so that oil dripping from the end of the drain tube collects inside the tray and does not soil the floor.

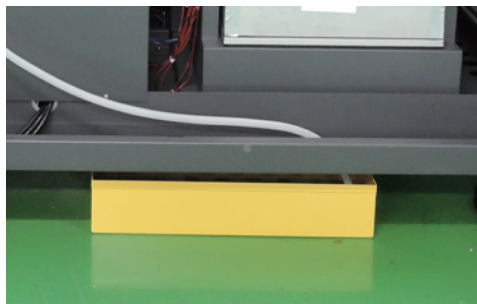

- 3 Open the cover on the opposite side and check that the powder collection tray is fully inserted.

! IMPORTANT

- If the machine is operated with the powder collection tray not fully inserted, powder may scatter onto the floor and cause contamination.

! Note

- The powder collection tray is pre-installed and is not an included accessory; however, check that it is properly installed.

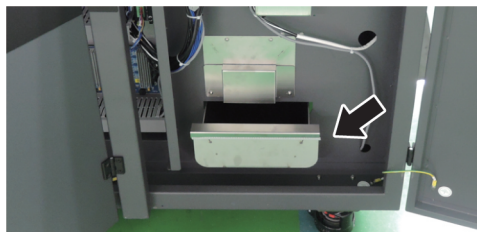

- 4 Open the powder box cover on the top surface and install the guide brackets on both ends of the media.

✎ TIPS

- They are magnetically attachable and detachable, and their positions can be adjusted according to the media's width.

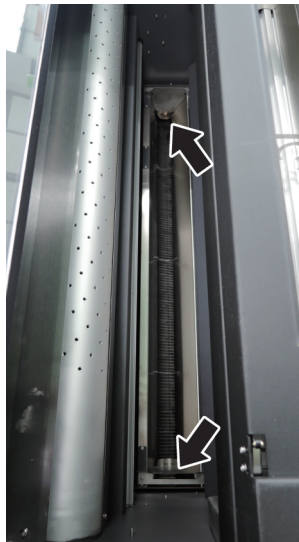

2.4 Other items required

Prepare the following items along with the supplied accessories:

- Film roll (media) used for printing

When selecting media, use media suitable for Direct to Film (DTF) applications, and be sure to perform print tests in advance, including printing on the printer and subsequent processes such as transfer, to confirm that satisfactory output results can be obtained. Even if a printer supports a particular media type, this machine may not be compatible with it.

- Supported media width: 23.6 to 31.9 in. (600 to 810 mm)
- Maximum media thickness: 0.02 in. (0.5 mm) or less
- Recommended media material: PET



WARNING

- Be sure to confirm the heat resistance of each type of media before use. The preset temperature of this machine is based on PET film. Operating this machine at a temperature exceeding the heat resistance of the media may cause deformation, discoloration, unusual odors, adhesion to the oven, fire, burns, or product malfunction.

- Recommended adhesive powder: Thermoplastic polymer

When selecting powder, use a powder suitable for Direct to Film (DTF) applications, and be sure to perform print tests in advance, including printing on the printer and subsequent processes such as transfer, to confirm that satisfactory output results can be obtained. If the powder particle size is too fine, it may scatter easily or be more likely to adhere inside the machine when moisture is absorbed. If the powder particle size is too coarse, uniform transfer may not be possible.



WARNING

- Be sure to confirm the heat resistance of each type of powder before use. The preset temperature of this machine is based on thermoplastic polyurethane powder. Operating this machine at a temperature exceeding the heat resistance of the powder may cause discoloration, unusual odors, adhesion to the oven, fire, burns, or product malfunction.

- A power plug suitable for the power supply type and plug shape at the installation location

2.5 Power connection

- 1 Connect a power plug suitable for the power outlet shape at the installation location to the end of the power cable (three wires).

TIPS

- As shipped from the factory, the power cable terminates in three exposed wires.
- The black cable is labeled “L”; the white cable, “N”; and the green and yellow cable, “PE.”

Depending on the region, these correspond to L1 (L), L2 (N), and N (PE).

Example showing the power plug connected to the cable and plugged into the power source

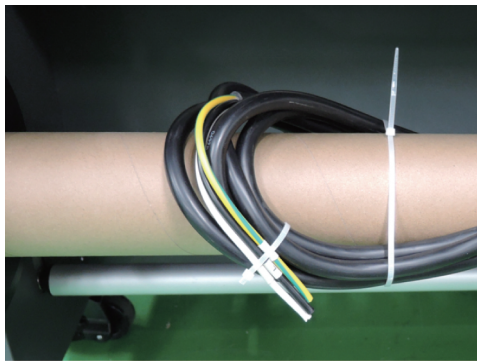

WARNING

- Connection of the power plug must be performed by a qualified person or someone with sufficient knowledge. Regarding requirements governing electrical work qualifications, follow the laws and regulations of the country in which the machine is being installed. Incorrect wiring may cause electric shock, fire, or product malfunction.
- Be sure to connect the ground.
Failure to do so may cause electric shock or malfunction.
- When securing the cable, do not forcibly bend or crush it.
Doing so may cause fire or electric shock.
- Do not handle the power plug with wet hands.
Otherwise, it may cause electric shock.

2.6 Power operations

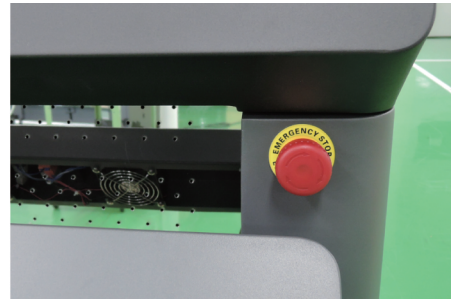

Turning on the power

- 1 Check that the emergency stop buttons (red) at the two locations—next to the top operation panel and on the right side of the rear media winding unit—are not pressed down.
If a button is pressed down, rotate it in the direction of the arrow (clockwise) to return it to its original position.
- 2 After connecting the power plug to the outlet for the first time or after releasing the emergency stop button, press the reset button (black).

TIPS

- The power may not turn on unless the reset button (black) is pressed.

- 3 Press the power button (green) to turn on this machine.

Turning off the power

- 1 Pressing the power button (green) again causes the button to pop up and turns off the power of this machine.

Performing an emergency stop

- 1 In an emergency, pressing either of the emergency stop buttons (red) at the two locations—next to the top operation panel or on the right side of the rear media winding unit—will stop operation.

Chapter 3

Basic Information

3.1 Specifications

Environmental requirements	Storage	0 to 40 °C (32 to 104 °F), 20 to 85% RH (no condensation)
	Working environment	18 to 30 °C (64.4 to 86 °F), 20 to 85% RH (no condensation)
	Recommended print environment	20 to 28 °C (68 to 82 °F), 35 to 65% RH (no condensation)
	Power	Single-phase 200 to 240 VAC 50/60 Hz, 16 A
	Power consumption (standby)	400 W
	Power consumption (operation)	4000 W
Size	Dimensions	Length 76.8 in. (1950 mm) × Width 44.1 in. (1120 mm) × Height 41.7 in. (1060 mm)
	Weight	400 kg (882 lb)
Supported media	Media width	24 to 32 in., or 600 to 810 mm
	Media thickness	Max. 0.02 in. (0.5 mm)
	Maximum media weight (when wound)	13 kg (29 lb) (including paper core)
	Maximum media diameter (when wound)	7.9 in. (200 mm) (including paper core)
Oven	Transport speed	Max. 1874 in./hr (47.6 m/hr)
	Set temperature	Max. 150 °C (302 °F)
Powder cycling function		Available
Safety mechanisms	Emergency stop button	Two locations (operation panel, media winding unit)
	Sensor	Powder box cover open/close sensor Heater oven cover open/close sensor Winding cover (roll drive unit) open/close sensor
Consumable supplies		HEPA filter Activated carbon filter
Environmental function		Exhaust air purification using two built-in filters User-replaceable Collection of oil condensed from exhaust air

3.2 Names of each component

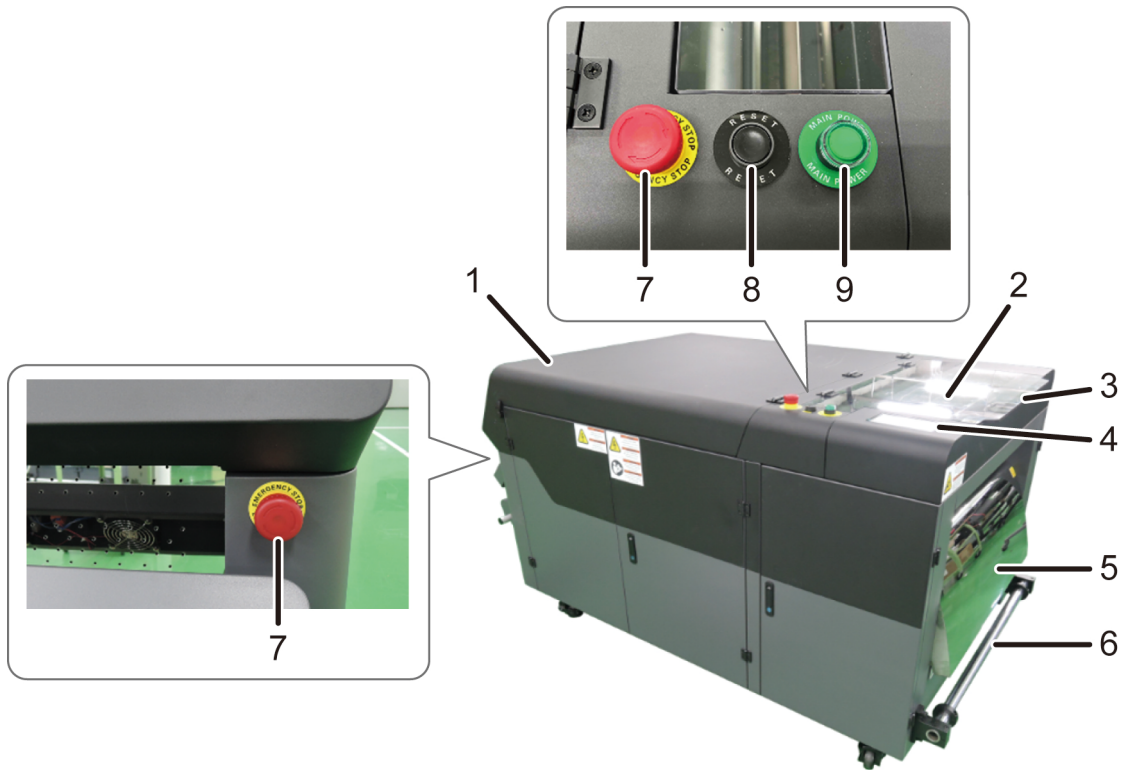

No.	Name
1	Heater oven cover
2	Powder box
3	Powder box cover
4	Operation panel
5	Preheater
6	Printer connection bracket (partial)
7	Emergency stop button
8	Reset button
9	Power button

Chapter 3

Basic Information

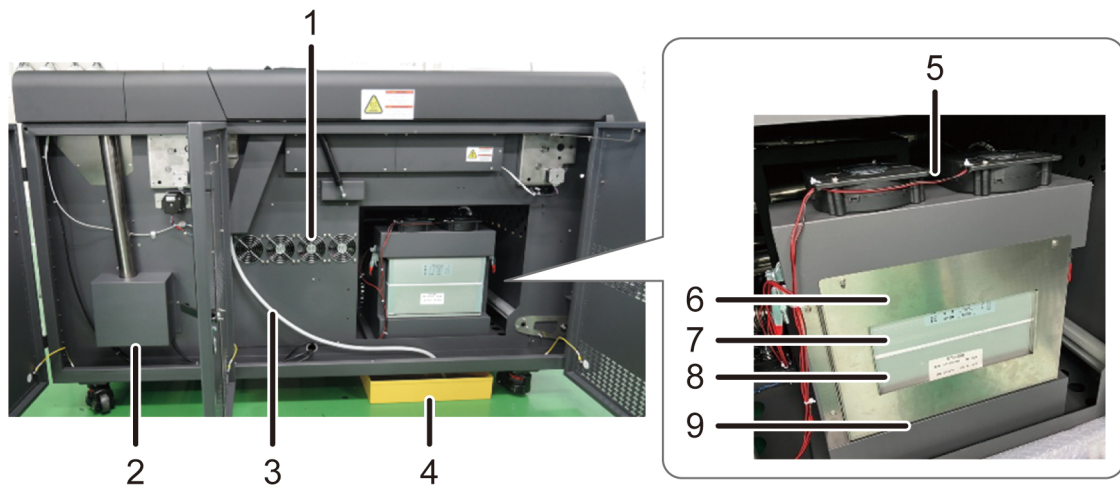

No.	Name
1	Internal exhaust fan
2	Powder cycling mechanism
3	Drain tube
4	Waste oil tray
5	Exhaust duct fan unit
6	Filter protection cover
7	HEPA filter
8	Activated carbon filter
9	Pre-filter (lower inside the cover)

Chapter 3
Basic Information

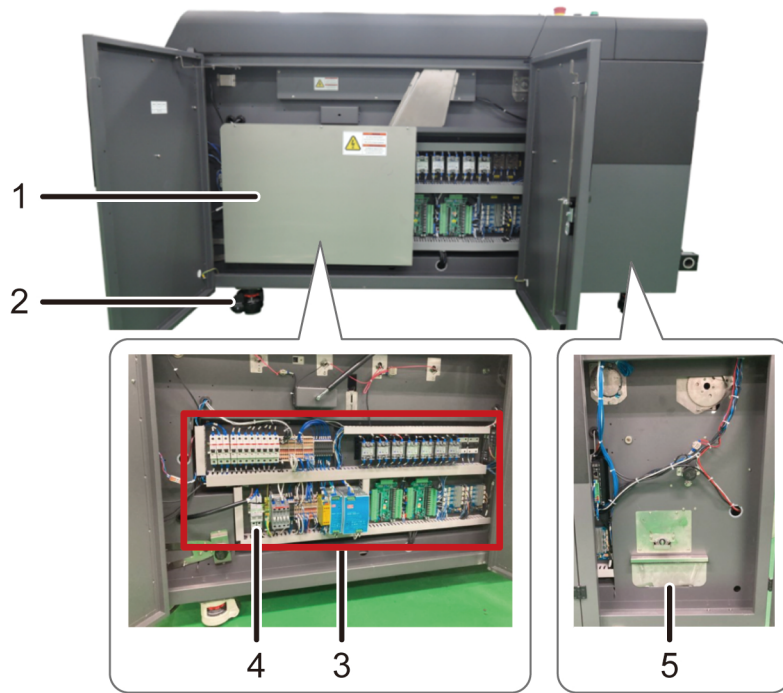

No.	Name
1	Power unit protection cover
2	Casters (four locations)
3	Electrical components
4	Main breaker
5	Powder collection tray

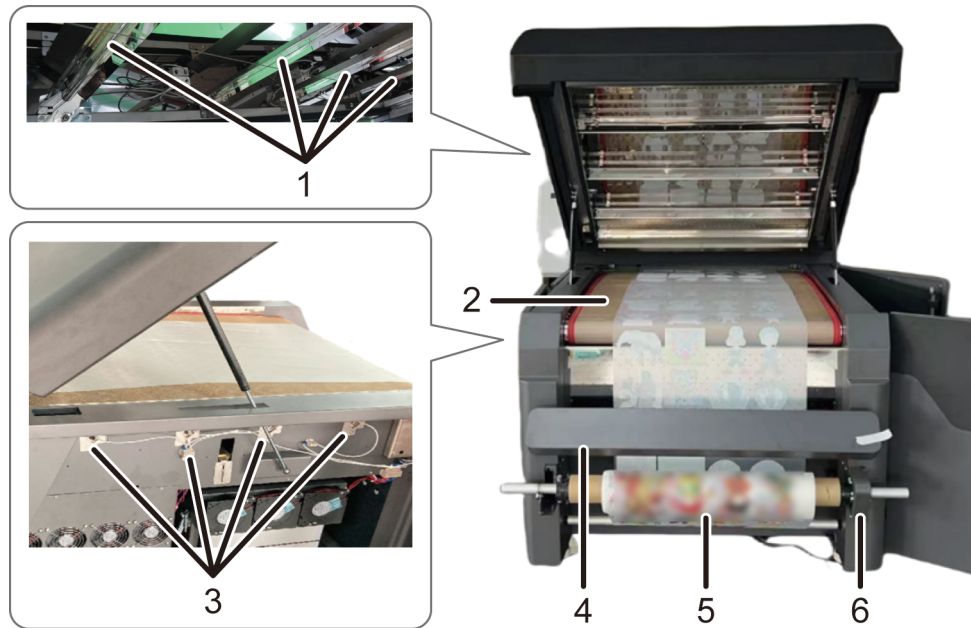

No.	Name
1	Upper heater tubes (total: 4)
2	Media transport belt
3	Lower heater tubes (total: 4)
4	Media cooling fan unit
5	Winding roll
6	Winding cover



No.	Name
1	Guide bracket
2	Powder cycling tray
3	Vacuum roll
4	Powder shaking mechanism

3.3 Description of sensors

3.3.1 Safety-related sensors



No.	Name
1	Heater oven cover sensor
2	Winding cover sensor
3	Powder box cover sensor

3.3.2 Operation-related sensors



No.	Name
1	Winding sensor roll
2	Powder sensor
3	Film (media) sensor

3.4 Panel menu list

The operation panel is a touch panel.

When the power is turned on, the language selection screen is displayed first. Select a language, and then the Home screen appears.



Home screen

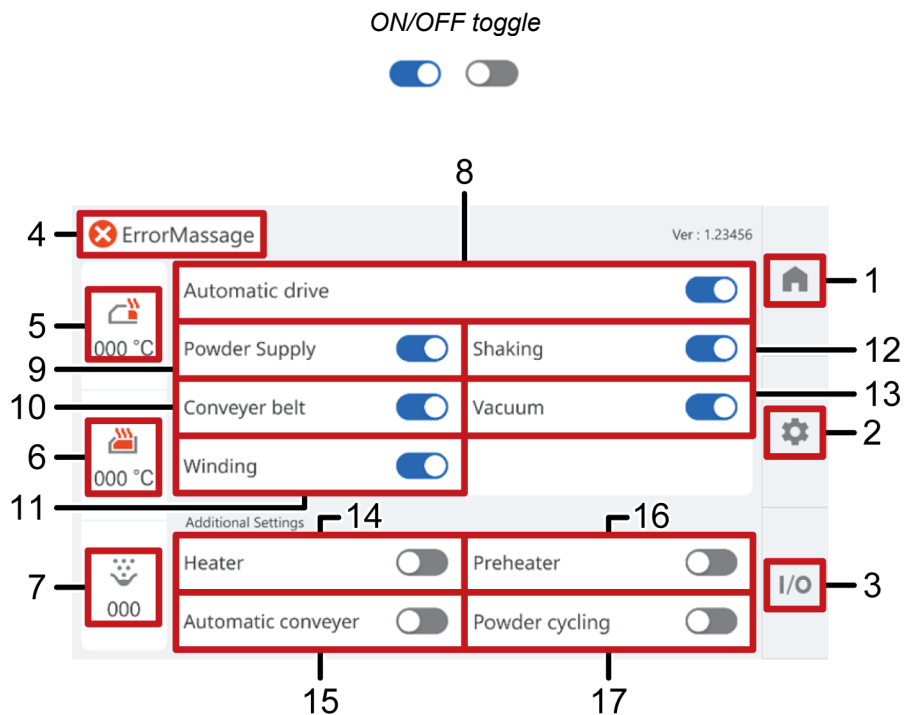

No.	Function
1	Return to the Home screen
2	Enter the parameter setting screen
3	Enter the Input/Output confirmation screen
4	Displays error messages
5	Displays the detected temperature of the preheater
6	Displays the detected temperature of the oven  : Heater idling status

No.	Function
7	Powder amount on the media (unit: powder sensor detection sensitivity 0 to 100)
8	Automatic/Manual operation selection
9	Powder supply from the powder box
10	Conveyer belt drive
11	Media winding
12	Powder shaking operation
13	Media suction by the vacuum roll
14	Heater
15	Automatic conveyer (transport regardless of sensor detection status)
16	Preheater
17	Powder cycling

Parameter setting screen

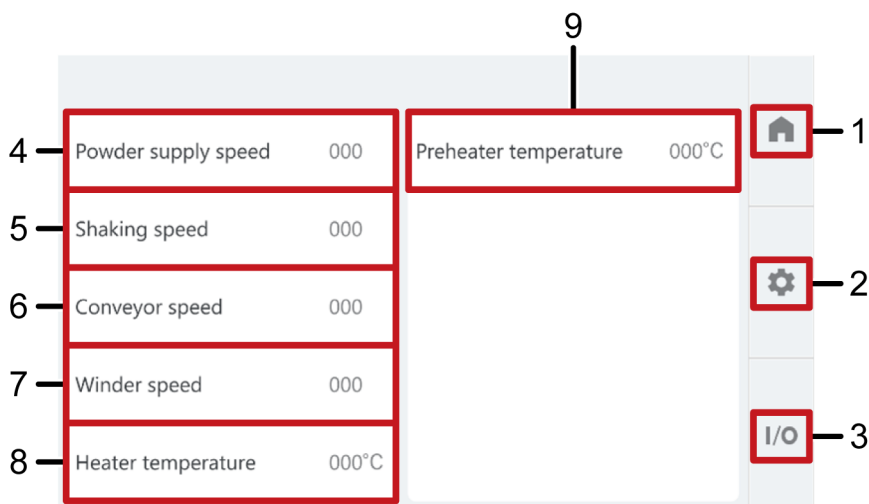

No.	Function	Initial value	Setting range
1	Return to the Home screen	-	-
2	Enter the parameter setting screen	-	-
3	Enter the Input/Output confirmation screen	-	-
4	Powder supply speed	50	1-100
5	Powder shaking speed	80	1-100
6	Conveyer belt speed	40	1-100
7	Winding speed	23	1-100
8	Heater temperature	130	1-150
9	Preheater temperature	40	1-50

Input/Output confirmation screen: Checking is not required during normal operation.

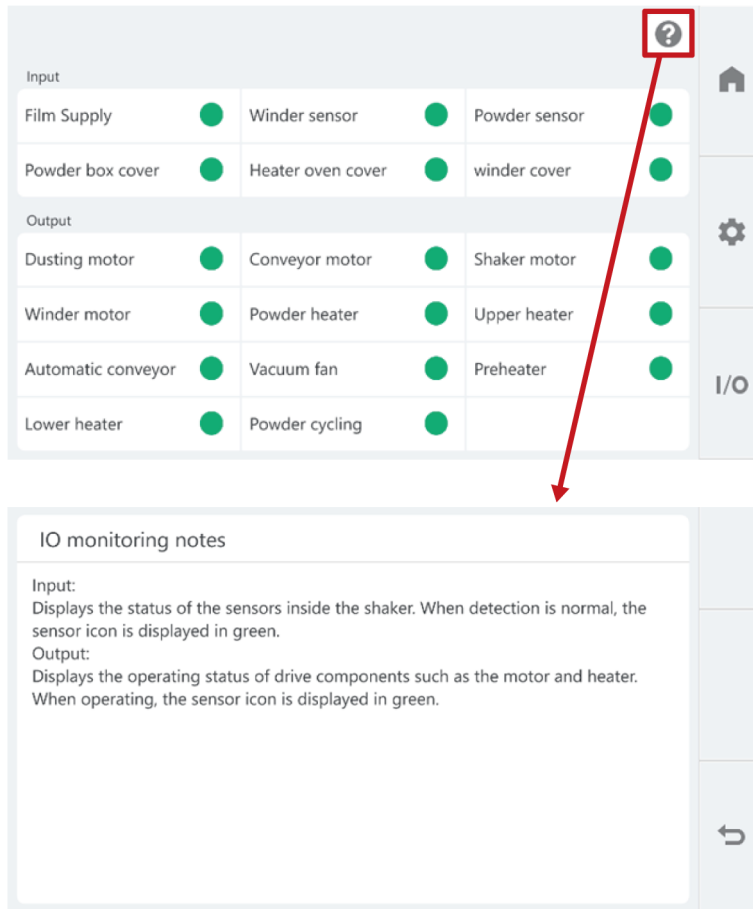

Chapter 4

Basic Operations

4.1 Loading the media

CAUTION

- When loading media, be careful not to bump, rub, or pinch your hands or fingers. Failure to do so may cause injury.
- When opening the heater oven cover for media installation or replacement, and after closing the cover, ensure that the heater and the media do not come into contact.
Heat from the heater may deform or melt the media, causing smoke, abnormal odors, fire, or malfunction.

- 1 Feed the media from the printer side along the transport path, pass it under the winding sensor roll at the rear of the machine, and secure it to the winding roll with tape.

Note

- Secure the media to the winding roll so that the printed surface is wound inward.

TIPS

- For automatic operation triggered by the machine's sensor detection in response to media transport from the printer side, it is necessary to place a certain amount of powder on the media and have the machine's powder sensor detect the powder weight. Refer to the Instruction Manual for operating procedures.

Diagram showing the media transport path viewed from the side, indicated by a red line

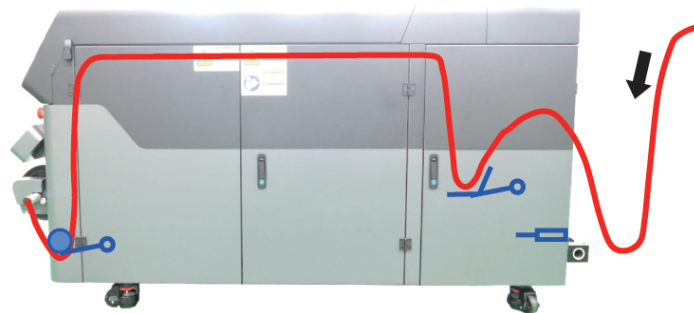

- 2 Open the heater oven cover and check that the media is set straight.

Check that the media is not lifted so that it does not contact the heater when the cover is closed.

 **TIPS**

- Set the media so that it is straight without distortion along the transport direction, with uniform margins on both the left and right sides across the width at all transport positions, and without partial lifting or sagging. This setup helps prevent skewing and allows stable transport and winding.
- When this machine is used with a DTRX100 printer and 23.6-in. (600-mm) -wide media is set right-aligned on the printer, the left margin will be wider and the right margin narrower than those shown in the figure below.



3 Set the media so that it rests on the guide brackets at both ends of the media.

Adjust the positions of the guide brackets according to the media width.

- Reference position when using 31.5-in. (800-mm) -wide media: (a)
- Reference position when using 23.6-in. (600-mm) -wide media: (b)
- Reference position when using 31.5-/23.6-in. (800-/600-mm) -wide media: (c)

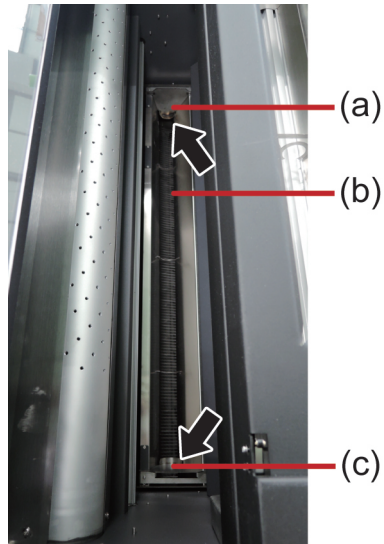

4.2 Loading the powder

CAUTION

- Powder will scatter during loading. Wear vinyl gloves, a mask, and protective goggles, and ensure sufficient ventilation during work.

- 1 Open the powder box cover on the top surface and load powder into the powder box.
Spread the powder evenly in the width direction inside the powder box to make the powder height uniform.

TIPS

- The initial amount of powder to be loaded should be approximately 2 kg (4 lb). Use a height at which the powder does not contact the lower part of the metal pipe inside the box as a guideline.
Check whether the weight detection of the powder accumulated on the media is normal and whether the powder adheres uniformly to the printed surface, and adjust the powder amount as necessary.

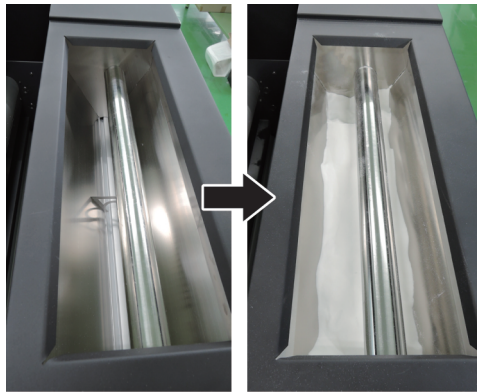

- 2 Scatter a certain amount of powder onto the media so that the powder sensor can detect it.

Initially, add approximately 800 g (28 oz) of powder manually, then make fine adjustments using the ON/OFF setting of [Powder Supply].

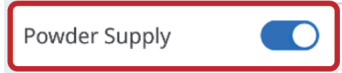

! Note

- Scatter powder onto the media, spread it evenly across the width, and accumulate an amount of powder on the media so that the powder sensor detection sensitivity is approximately 65 to 100.



✎ TIPS

- When [Powder Supply] in the panel menu is turned OFF, powder scattering stops.
- If powder is spread evenly and accumulated on the media before starting automatic operation, powder adhesion to the media tends to stabilize more quickly after automatic operation starts.
- If you attempt to add powder only by turning [Powder Supply] ON without adding powder manually until the powder sensor detects the powder, it may take some time; therefore, manual addition is recommended at the beginning.

4.3 Storage of media and powder

- Store unopened media and powder (consumables) in a cool, dark place or under the recommended conditions and methods for each consumable.
- After opening and using consumables, we recommend storing any remaining consumables under the recommended conditions and methods for each consumable or sealing them tightly to prevent moisture ingress. The use of a desiccant is also recommended.
- If the machine is not used for an extended period with consumables set, we recommend removing the media, collecting the powder in a container or similar, and storing them in the same manner as described above.
- Consumables may deteriorate in performance if a long time has passed after opening or if they are exposed to a high-humidity environment.

If the performance of the media deteriorates, it may lead to reduced print quality, such as discoloration, ink bleeding, or ink dripping during printing.

If the performance of the powder deteriorates, it may solidify into clumps instead of remaining a fine powder, making it impossible to scatter the powder evenly on the printed surface or causing it to adhere inside the machine.

- When using consumables that have been stored in an environment different from the operating environment, if condensation is observed on the consumables, their containers, or packaging, place them in the operating environment and allow sufficient time for acclimation, and use them only after the condensation has dissipated.
- When disposing of consumables, follow the disposal methods specified for each consumable and comply with the laws and rules of the place and region of use.

4.4 Automatic operation procedure

This is a method of operation in which printing by the printer and powder fixing by this machine are linked.

When using a Brother DTRX100 printer, connect and secure the printer and this machine. Refer to [Connecting to the printer on page 16](#) for the connection method.

Load the media on this machine. Refer to [Loading the media on page 33](#) for the loading method.

Load an appropriate amount of powder into this machine. Refer to [Loading the powder on page 36](#) for the loading method.

4.4.1 Operating principle

In automatic operation mode, operation is performed, and the media is transported when all three sensors listed below (① to ③) detect the media. If any one of the three sensors does not detect, operation stops and the system enters the idling state.

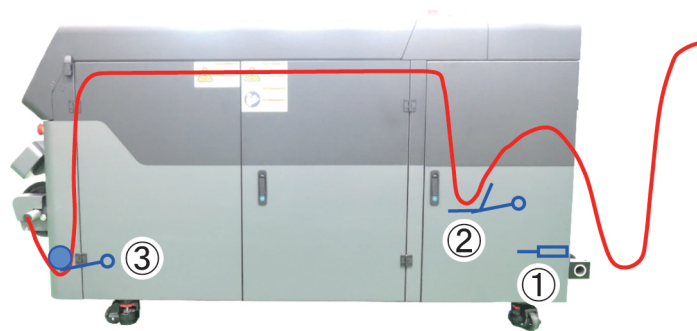

①	Film (media) sensor	The sensor detects when printed media accumulates and hangs down between the printer and this machine.
②	Powder sensor	<p>Powder scattered from the powder box accumulates on the media, and the weight of the powder causes the film to hang down and press the powder sensor by a certain amount, which is then detected.</p> <p>In automatic operation mode, if the detected amount is small, powder scattering from the powder box continues, and when the detected amount reaches or exceeds a certain level, powder scattering from the powder box stops.</p>
③	Winding sensor roll	<p>It is located below the winding roll, and the shaft of this roll moves up and down. When media exiting the heater oven accumulates without being taken up, no media tension is applied to the winding sensor roll, and the shaft of this roll moves to the lowered position. The sensor detects the lowered position of the roll shaft.</p> <p>When winding progresses sufficiently and the media slack is eliminated, the shaft is pushed up by media tension, and the sensor no longer detects the shaft position.</p>

In the idling state, the heater oven temperature is maintained at approximately 10 °C (50°F) lower than the set value.

In addition, the oven detected temperature icon in the panel menu changes to the idling state (🔥).

4.4.2 Operating procedure

- 1 When [Automatic drive] is set to ON in the panel menu, [Powder supply], [Conveyor belt], [Winding], [Shaking], and [Vacuum] are turned ON together.

In this state, the operation starts when the three sensors described above detect the media.

ON/OFF toggle

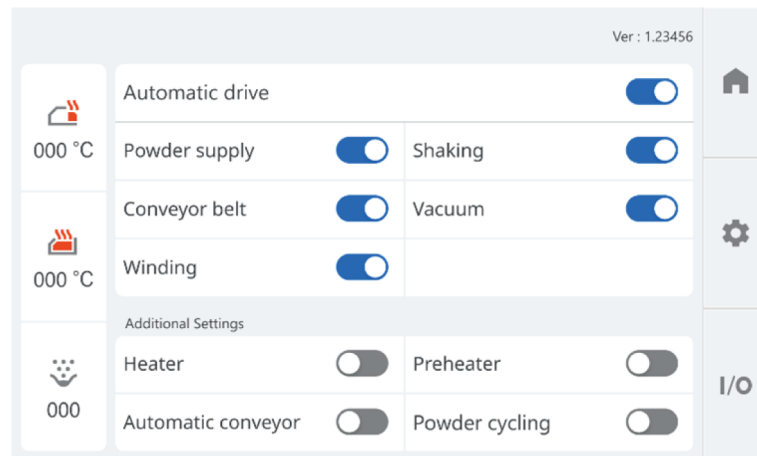

- 2 Neither [Heater] nor [Preheater] turns ON when [Automatic drive] is enabled, so each must be turned ON manually.

Because it takes time for the heater oven to reach the set temperature, we recommend turning [Heater] ON in advance and allowing it to stabilize at the set temperature before operation.

WARNING

- Do not leave the machine unattended during automatic operation, and ensure that its condition can be checked and operations can be performed at any time. If an unexpected problem occurs, it may not be possible to respond, which may result in media damage or contamination, product failure, or fire.

IMPORTANT

- While [Automatic drive] is ON, media transport starts when all three sensors detect the media, even if the oven detected temperature has not reached the heater temperature setting.

If the oven temperature is insufficient, print quality may deteriorate. Operate the machine after confirming that the oven detected temperature has risen and is in a range between the set temperature and approximately 10°C (50°F) below the set temperature, and has stabilized.

Note

- If idling continues due to the printer stopping printing and the printed media remains inside the heater oven for an extended period, the print quality of the areas remaining in the heater oven may deteriorate. We recommend checking the print quality of areas that remained for an extended period.

TIPS

- Because [Powder cycling] does not operate in conjunction with [Automatic drive], turn it ON manually, as necessary. The ON/OFF setting of [Powder cycling] is retained.
- [Automatic conveyor] can be operated only when [Automatic drive] is ON. It is normally OFF, but when set to ON, operation continues regardless of detection by the three sensors. For example, set [Automatic conveyor] to ON when you want to perform powder fixing on the final portion of the media after the media roll has been completely used.
- When [Automatic drive] is ON and the machine is in the idling state, the heaters also remain in the idling state. In this condition, the temperature does not rise to the heater set temperature, and the oven detected temperature is limited to approximately 10°C (50°F) below the set temperature.
(For example, when the heater set temperature is 130°C (266°F), the oven detected temperature does not rise above approximately 120°C (248°F) during idling.)
- After turning [Heater] ON, it takes approximately 15 to 20 minutes in an air-conditioned environment for the oven detected temperature to reach 120 to 130°C (248 to 266°F).
In cold environments, such as winter mornings, it may take 30 minutes or longer.

4.5 Setting values for printer-linked operation

When using a Brother DTRX100 printer, it is recommended to use the settings recommended for this machine according to the media width and the printer-side print settings (number of passes).

Media width: 23.6 in. (600 mm)

Print mode	Print speed (m/h)	Powder supply speed	Powder shaking speed	Conveyer belt speed	Winding speed	Heater temperature	Preheater temperature
5 pass	28.6	50	80	66	47	130°C (266°F)	40°C (104°F)
6 pass	23.8	50	80	50	33	130°C (266°F)	40°C (104°F)
9 pass	15.9	50	80	21	10	130°C (266°F)	40°C (104°F)
12 pass	11.9	50	80	7	1	130°C (266°F)	40°C (104°F)

Media width: 31.5 in. (800 mm)

Print mode	Print speed (m/h)	Powder supply speed	Powder shaking speed	Conveyer belt speed	Winding speed	Heater temperature	Preheater temperature
5 pass	24.0	50	80	54	34	130°C (266°F)	40°C (104°F)
6 pass	20.4	50	80	40	23	130°C (266°F)	40°C (104°F)
9 pass	13.5	50	80	15	4	130°C (266°F)	40°C (104°F)
12 pass	9.9	50	80	5	1	130°C (266°F)	40°C (104°F)

IMPORTANT

- Do not set the "conveyer belt speed" or "winding speed" of this machine slower than the transport speed on the printer. Media may accumulate between the printer and this machine or at the heater oven outlet, and contact between the printed surfaces of multiple media may cause media contamination.

 **Note**

- If the "conveyer belt speed" or "winding speed" of this machine is set too fast compared with the printer-side transport speed, the machine will frequently enter the idling state, the heater temperature will fluctuate frequently, and the temperature will become unstable, which may reduce print quality. It is recommended to use the recommended setting values.

Chapter 5

Maintenance

5.1 Confirmation before starting the operation

Checking and replenishing the powder level

- 1 Refer to [Loading the powder on page 36](#), and add powder as necessary, so that the powder level in the powder box is appropriate, then spread it evenly in the width direction.

CAUTION

- Powder will scatter during loading. Wear vinyl gloves, a mask, and protective goggles, and ensure sufficient ventilation during work.

- 2 Refer to [Loading the powder on page 36](#), and scatter an appropriate amount of powder onto the media, then spread and accumulate it evenly in the width direction.
- 3 Check that there is no abnormality in the detection sensitivity of the powder sensor.
- 4 Turn [Powder cycling] ON to perform powder circulation, and check that the powder is supplied to the powder box without clogging.

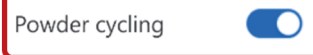

TIPS

- If the amount of powder accumulated in the "powder cycling tray" located below the powder sensor is insufficient, powder will not be supplied to the powder box even if powder circulation is performed.

5.2 Daily maintenance

5.2.1 Reusing the powder

Check the condition of the powder accumulated in the powder collection tray daily and reuse the powder.

- 1 Open the cover below the operation panel and remove the powder collection tray.

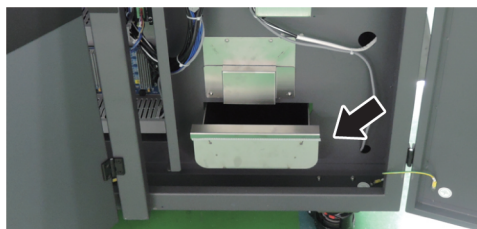

- 2 Open the powder box cover and load the powder accumulated in the tray into the powder box from the top.

⚠ CAUTION

- During powder loading and cleaning operations, powder may scatter, so wear vinyl gloves, a mask, and protective eyewear, and ensure sufficient ventilation.

ⓘ Note

- If the powder accumulated in the tray is contaminated, wet, or has formed large clumps, do not reuse it and dispose of it. Powder adhesion to the printed surface on the media may become uneven, which may reduce print quality.

5.2.2 Cleaning scattered powder and oil

- 1 Wipe off and collect powder adhering to areas other than the powder box and powder collection tray, as well as powder adhering to the floor around this machine, using a dry cloth or similar, or clean it using a vacuum cleaner.

Refer to [Storage of media and powder on page 38](#) when disposing of powder.

⚠ CAUTION

- During powder loading and cleaning operations, powder may scatter, so wear vinyl gloves, a mask, and protective eyewear, and ensure sufficient ventilation.

- 2 Wipe off oil adhering to covers around the waste oil tray and to the floor using a dry cloth or similar.

Refer to [Installation of supplied accessories on page 16](#) and check that the waste oil tray is installed directly below the drain tube.

⚠ CAUTION

- If waste oil gets into your eyes or onto your skin, it may cause inflammation. During cleaning, wear protective gloves, a mask, and protective eyewear, and if it gets into the eyes, do not rub them and immediately rinse with water.

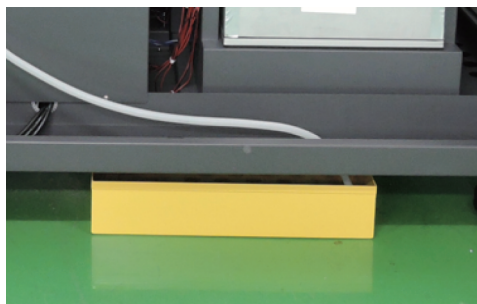

5.3 Weekly maintenance

5.3.1 Checking and disposing of waste oil

- 1 Check the amount of waste oil accumulated in the waste oil tray.
- 2 If waste oil has accumulated to a level where the liquid surface is visible, transfer it to another sealable container and dispose of it, then wipe the tray clean with a dry cloth or similar.

Also refer to [Waste oil handling procedure on page 54](#).

CAUTION

- If waste oil gets into your eyes or onto your skin, it may cause inflammation. During disposal or cleaning, wear protective gloves, a mask, and protective goggles. If waste oil enters the eyes, do not rub and immediately rinse with water.

Note

- During cleaning of the waste oil tray, waste oil may drip from the drain tube and contaminate the floor, so place a cloth directly below the drain tube or take similar measures to prevent the oil from spreading.

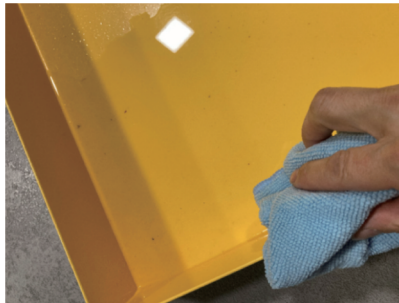

5.3.2 Checking the oil contamination of the filter section

- 1 Open the machine cover.

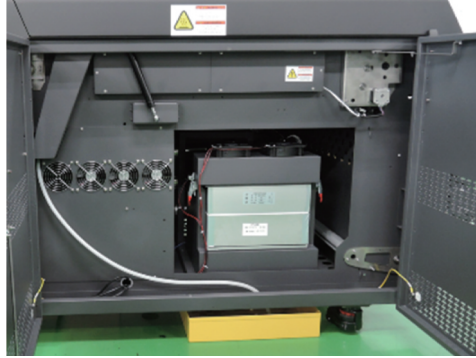

- 2 Check each component of the filter section (the filter protection cover, the three types of filters, and the exhaust duct fan unit), as well as any oil contamination around them, and wipe them clean with a cloth or similar material, as necessary.

CAUTION

- If waste oil gets into your eyes or onto your skin, it may cause inflammation. During disposal or cleaning, wear protective gloves, a mask, and protective goggles. If waste oil enters the eyes, do not rub and immediately rinse with water.

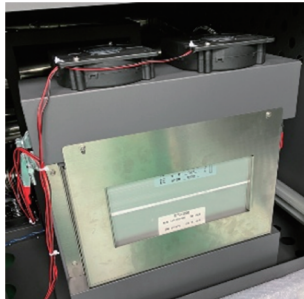

5.3.3 Cleaning oil inside the heater oven cover

- 1 Open the heater oven cover.

! WARNING

- When opening the heater oven cover, turn off the power and confirm that the temperature has decreased. Failure to do so may result in burns.

- 2 Wipe off waste oil adhering to the outer periphery inside the cover and the lower areas in contact with the cover using a dry cloth or similar material.

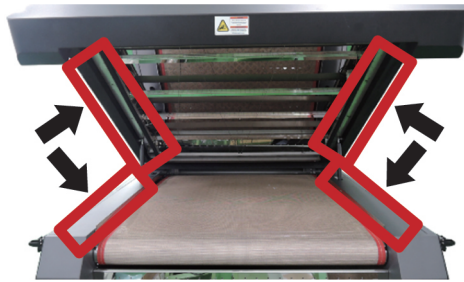

! CAUTION

- If waste oil gets into your eyes or onto your skin, it may cause inflammation. During disposal or cleaning, wear protective gloves, a mask, and protective goggles. If waste oil enters the eyes, do not rub and immediately rinse with water.

! Note

- The area near the hinge inside the cover is part of the exhaust air intake path and is prone to waste oil accumulation, so check it carefully.



5.3.4 Cleaning the heater tubes and stainless-steel parts

- 1 Open the heater oven cover.

WARNING

- When opening the heater oven cover, turn off the power and confirm that the temperature has decreased. Failure to do so may result in burns.

- 2 Wipe off waste oil and dust adhering to the heater tubes at the center inside the cover and the stainless-steel parts behind them using a dry cloth or similar material.

CAUTION

- If waste oil gets into your eyes or onto your skin, it may cause inflammation. During disposal or cleaning, wear protective gloves, a mask, and protective goggles. If waste oil enters the eyes, do not rub and immediately rinse with water.
- Because the heater tubes are made of glass, handle them with care during cleaning. Failure to do so may result in injury or malfunction.

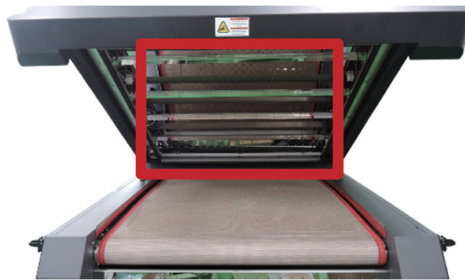

5.4 Monthly maintenance

CAUTION

- During powder transfer, loading, and cleaning operations, powder may scatter, so wear vinyl gloves, a mask, and protective eyewear, and ensure sufficient ventilation.

TIPS

- If reusable powder remains inside this machine, transfer it to another container or similar before cleaning.

- 1 Remove powder that has adhered inside the powder collection tray using a dry cloth or similar, and clean the tray.

Remove contaminated powder, wet powder, and powder that has formed clumps as well.

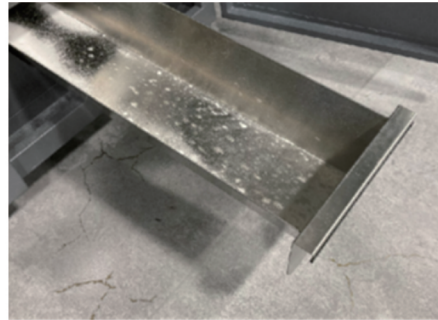
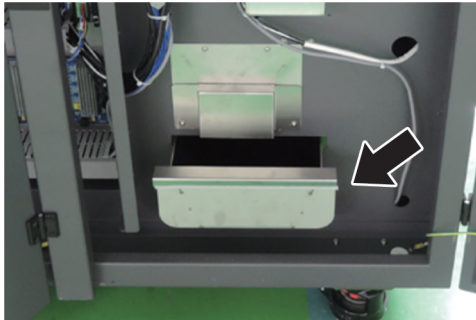

- 2 Similarly, remove such powder from inside the powder box and clean it.

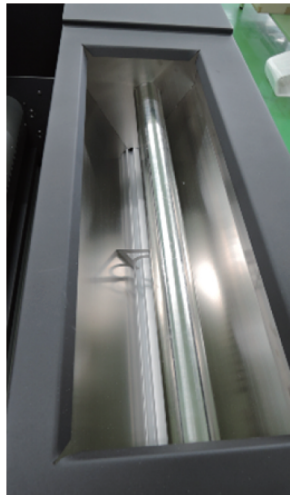

5.5 Regular filter replacement

Three types of filters (pre-filter, activated carbon filter, and HEPA filter) are installed in the exhaust path of this machine. Of these, replace the HEPA filter and the activated carbon filter every 3 to 6 months. If the filters become dirty more quickly due to a high operating rate or other reasons, replace them at shorter intervals, as necessary.

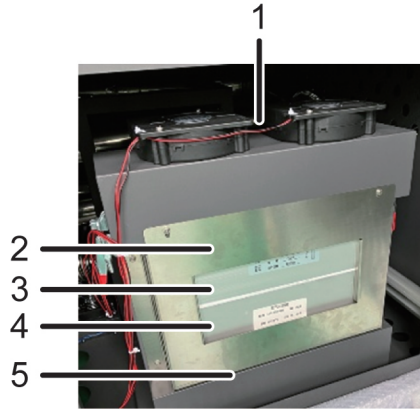

No.	Name
1	Exhaust duct fan unit
2	Filter protection cover
3	HEPA filter
4	Activated carbon filter
5	Pre-filter (lower inside the cover)

! Note

- The HEPA filter and activated carbon filter are consumable items. They cannot be reused by washing or other cleaning methods.
- If smoke is generated during operation or if the odor is stronger than usual, stop operation, check the condition of the filters, and replace the filters.

Filter replacement procedure

- 1 Open the side cover on the left side as viewed from the rear of the machine.



- 2 Remove the filter protection cover.
- 3 Release the left and right fasteners of the fan unit.

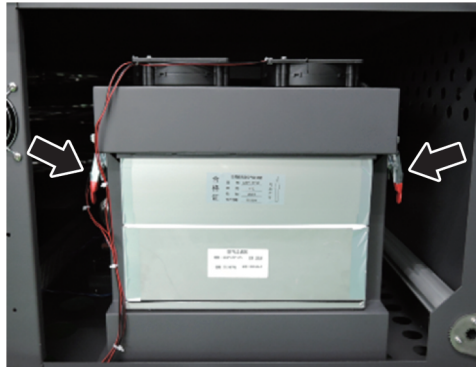

- 4 Slide the fan unit toward the rear and place it there.

! IMPORTANT

- When sliding the fan unit toward the rear, pay attention to the length of the harness connected to the fan. If the harness is accidentally damaged, a fan malfunction may occur, which can cause smoke, abnormal odors, or product failure.



- 5 Remove the used HEPA filter and activated carbon filter.

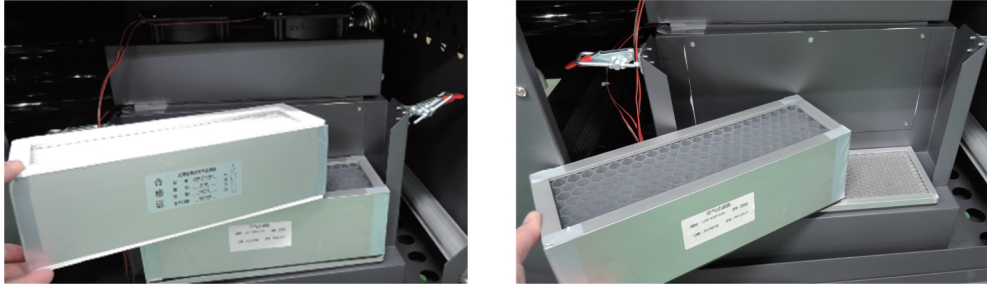

- 6 If oil contamination on the pre-filter or surrounding areas is noticeable, wipe it off with a dry cloth or similar material to remove the oil.

CAUTION

- If waste oil gets into your eyes or onto your skin, it may cause inflammation. During disposal or cleaning, wear protective gloves, a mask, and protective goggles. If waste oil enters the eyes, do not rub and immediately rinse with water.

Note

- Dirt on the pre-filter may be removed by washing with water; however, ensure that it is thoroughly dried before reinstalling.

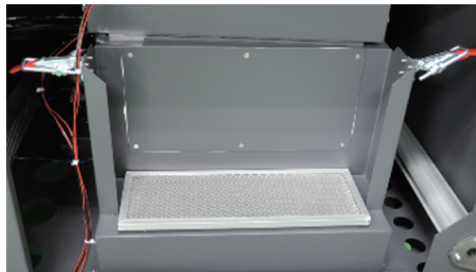

- 7 Install new HEPA and activated carbon filters.

Note

- Pay attention to the installation order so that the HEPA filter is on top and the activated carbon filter is below.

- 8 Place the fan unit on top of the filters and secure the left and right fasteners.

- 9 Install the filter protection cover and close the side cover.

Note

- Dispose of removed HEPA filters and activated carbon filters after use as industrial waste or metal composite waste, or in accordance with the laws and regulations of the place and region of use.

5.6 Waste oil handling procedure

- Collect the accumulated waste oil in a sealable container to prevent leakage.
- Place cloths or similar materials contaminated with waste oil into a vinyl bag or similar, seal it, and prevent oil contamination or leakage to the surrounding area.
- The disposal method for waste oil shall follow the disposal method for ink used in the DTRX100 printer. Confirm the ink disposal method and dispose of the waste oil in accordance with the location where this machine is used and local laws and regulations.
- Waste liquid from the DTRX100 printer may be mixed with the waste oil generated by this machine for disposal.

CAUTION

- If waste oil gets into your eyes or onto your skin, it may cause inflammation. During disposal or cleaning, wear protective gloves, a mask, and protective goggles. If waste oil enters the eyes, do not rub and immediately rinse with water.

5.7 When not used for a long period of time

- Disconnect the power plug from the main power source.
- Remove the media from the transport path.
- Remove the powder accumulated in the powder box and powder collection tray. At this time, turn [Powder cycling] ON to circulate the powder, transfer all powder in the circulation path to the powder box, and remove it.

Powder cycling



- Refer to [Monthly maintenance on page 50](#) to remove adhered powder and clean the area.
- Collect and clean the waste oil accumulated in the waste oil tray, as well as waste oil adhering to the filters and around the filters.
- When disposing of or storing the removed media and powder for future use, follow [Storage of media and powder on page 38](#) to dispose of or store them accordingly.

Chapter 6

Troubleshooting

6.1 In case of the following problems

Refer to the following to resolve the problem.

Media feeding is skewed

Probable Cause	Remedy	Reference
Is the machine connected to and secured to the printer?	If the printer and this machine are not aligned straight, media skew is more likely to occur.	Connecting to the printer on page 16
Is the media skewed when loaded?	Load the media so that the distance between the media and the left and right sides remains constant. Or adjust the media, as necessary.	Loading the media on page 33

The media bends at the powder sensor section

Probable Cause	Remedy	Reference
Are the guide brackets at both ends of the media correctly positioned at the media edges?	If the media rides up onto the guide brackets, it may bend.	Installation of supplied accessories on page 16
Is the media skewed?	If the media is skewed, it may ride up onto the guide brackets and bend.	Loading the media on page 33

The powder sensor does not detect properly

Probable Cause	Remedy	Reference
Is the amount of powder on the media insufficient?	Scatter additional powder.	Loading the powder on page 36
Is too much powder accumulated in the powder cycling tray located below the media?	Turn [Powder cycling] ON and continue powder circulation for a while to reduce the amount of powder in the powder cycling tray.	-

Powder continues to drop from the powder box

Probable Cause	Remedy	Reference
The gap between the powder scattering roller and the powder box may be too large.	Repeatedly turn [Powder Supply] ON and OFF and check when the powder stops dropping.	-

The printed surface is sticky after passing through the heater oven

Probable Cause	Remedy	Reference
Is the heater temperature setting too low?	Set it to the recommended value.	Setting values for printer-linked operation on page 42
Is the conveyer belt speed too fast?	Set it to the recommended value.	Setting values for printer-linked operation on page 42

The media deforms or discolours after passing through the heater oven Cracks appear on the printed surface after passing through the heater oven

Probable Cause	Remedy	Reference
Is the heater temperature setting too high?	Set it to the recommended value.	Setting values for printer-linked operation on page 42
Is the conveyer belt speed too slow?	Set it to the recommended value.	Setting values for printer-linked operation on page 42
Did the media remain inside the heater oven for an extended period while the machine was idling?	Avoid prolonged residence inside the heater oven.	-

Powder adhesion is uneven or insufficient in some areas

Probable Cause	Remedy	Reference
Is the amount of powder on the media insufficient? Is it uneven in the width direction?	Scatter additional powder and spread it evenly in the width direction.	Loading the powder on page 36
Are you using contaminated powder? Are you using powder that has clumped?	Replace it with new powder.	Loading the powder on page 36

Powder adheres to areas other than the printed surface

Probable Cause	Remedy	Reference
Is the powder brushing strength insufficient?	Set it to the recommended value. Alternatively, try changing the setting and check whether it improves.	Setting values for printer-linked operation on page 42
Are you using media that has been opened for a long time or media that has absorbed moisture?	Replace it with new media.	Loading the media on page 33

Powder does not circulate or is not supplied from the upper section

Probable Cause	Remedy	Reference
Is [Powder cycling] set to ON?	Set [Powder cycling] to ON in the panel menu.	Panel menu list on page 30
Is the amount of powder accumulated in the powder cycling tray insufficient?	If the powder is insufficient, the supply rate decreases. Add powder separately.	Loading the powder on page 36
Has powder solidified inside the circulation path?	Contact your dealer.	-
Is the circulation motor operating?	Contact your dealer.	-

Waste oil accumulates quickly

Probable Cause	Remedy	Reference
Is the machine operating at a high duty cycle?	Check the amount of waste oil and increase the collection frequency. At high duty cycles, waste oil accumulates more easily.	Weekly maintenance on page 46

Filters clog quickly

Probable Cause	Remedy	Reference
Is the machine operating at a high duty cycle?	Check the filter contamination and increase the filter replacement frequency. At high duty cycles, filters become dirty more easily.	Regular filter replacement on page 51

The machine does not start operating even though media is being transported from the printer in automatic operation mode

Probable Cause	Remedy	Reference
Is the horizontal distance between the film (media) sensor and the accumulated media too large?	Move the accumulated media closer to the film (media) sensor and check whether automatic operation starts.	-
Is the powder sensor detecting properly? Is powder accumulated on the media?	If the powder is insufficient, the powder sensor detection amount is inadequate, and the operation will not start. Scatter additional powder onto the media.	Loading the powder on page 36
Is the winding sensor roll shaft remaining raised even though there is no media tension?	Move the winding sensor roll by hand to lower the roll shaft.	-

Stronger-than-usual odor during operation

Probable Cause	Remedy	Reference
Is the heater temperature setting too high?	Set it to the recommended value. Alternatively, lower the heater temperature to the optimum value according to the media material.	Setting values for printer-linked operation on page 42
Are the filters clogged?	Replace the filters.	Regular filter replacement on page 51
Is the media contacting the heater tubes inside the heater oven?	After the temperature has decreased, open the heater oven cover and check and correct the media installation inside. If there is any dirt or adhesion on the heater tubes, clean them.	Loading the media on page 33 Weekly maintenance on page 46

Product inquiries

BROTHER INDUSTRIES, LTD.

<https://www.brother.com/>
1-5 Kitajizoyama, Noda-cho, Kariya
448-0803, Japan

Please note that the contents of this manual may differ slightly from the actual product purchased as a result of product improvements.